

Ben's Small Bible of Realistic Multiplayer Level Design

2004-11-11

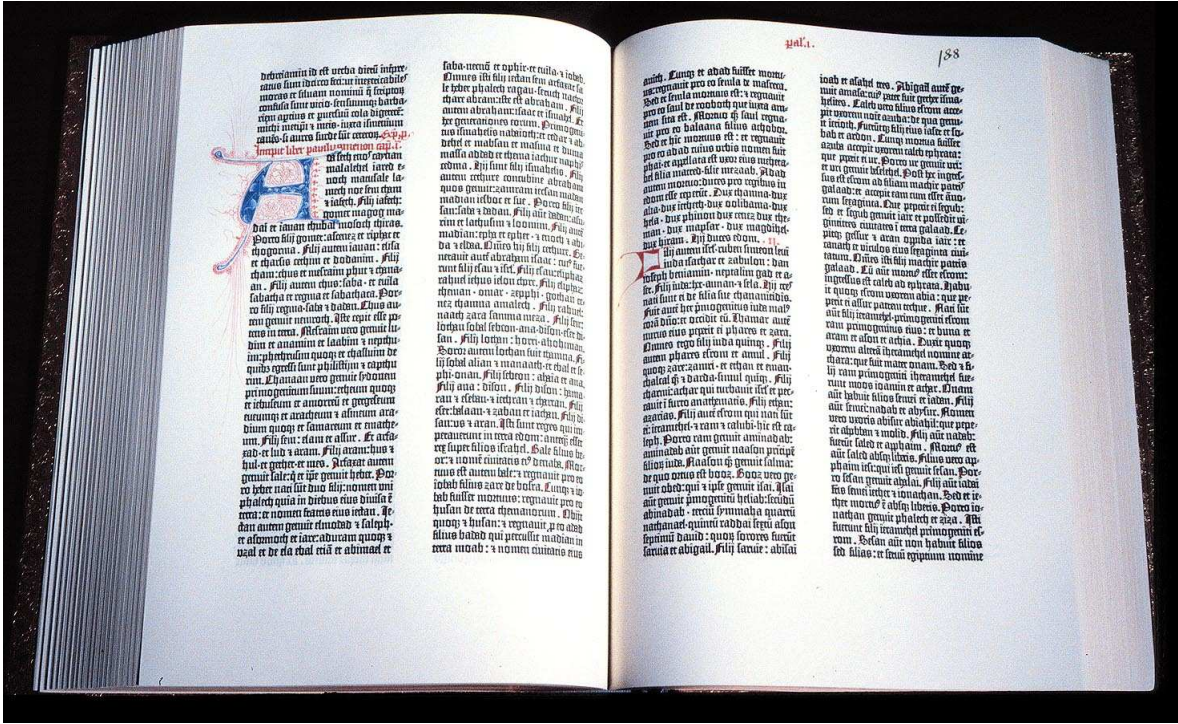

Ben's Small Bible of Realistic Multiplayer Level Design

Version 1.0

November 11, 2004.

Author: Benjamin Bauer © 2004 by Crytek GmbH – <http://www.crytek.com>

You are allowed to redistribute this document only for free as is, without modifications. Partially redistribution or any commercial exploitation is prohibited.



Contents

Introduction.....	3
Small Tale	3
Level Design Terminology	4
Basic Strategy Balance.....	6
Introduction	6
The first basic Layout Settings.....	6
Making it more complex	7
General Area Settings	8
Special Talk about open Battlefields	9
Strategic Summary	9
Improvements With Tactical Elements.....	10
Introduction	10
Battle Areas	10
Mission areas	17
Movement Modifiers	22
Hallways or what happened between the Areas	23
Spawn points	24
Stopping the Player.....	25
Tactical Summary	26
Navigation/Orientation in the Levels	27
Introduction	27
Eye Catcher/ Special Areas	27
Overview/ Understanding of the Level	28
Different Level Sizes	29
Art for Gameplay	32
Introduction	32
Lighting	32
Textures	33
Architecture & Geometry	33
What about Details and Beauty?	35
Sound for Gameplay.....	36
Round Based vs. Reinforcement Game modes.....	37
Mirrored vs. Uneven Map Layout	38
Realistic & Arcade	40
Game design vs. Level design.....	41
Creativity	42
Final Words & Questions	43

Introduction

I am writing this article to share my personal experiences and opinions about realistic multiplayer level design. Some of my old maps don't follow these rules and I made mistakes myself, but I learnt from my failures and by sharing this knowledge with you I hope you will make better maps without going through the same arduous learning process.

You should have a basic understanding of level design and I'll try to explain everything as simply as possible. Experienced mappers, even if you don't make multiplayer maps with realistic settings, should read it, too, because you might find some interesting aspects you didn't think about and as a good level designer never stops learning you may well learn something new. Personally, I am not limited to realistic settings but that is what I've worked on for the last few years. The level design for a sci-fi/ Wild West/ Stone Age/ cartoon multiplayer game with some tactical elements and teamplay is very similar.

For anybody who thinks these rules/schemes might be too systematic always remember: "You can only break the rules if you understand them in the first place!", in this aspect it is very similar to the art world.

In this article, I'll explain how to make a multiplayer map from scratch and then tell you how to improve it. At the end of the article we'll take a look at different gamemodes/layouts and how they might affect the levels design. As usual, I tried to write this article in an interesting fashion and added a lot of pictures and illustrations. Please don't be lazy and skip the examples, because I explain some important concepts in them. When I talk about players and teams I assume they all have similar skills and experience. It's not down to luck that hard-core gamers usually win against noobs, but in a balanced teammatch if one side consistently wins it might be because the level design is bad and that is what I want to talk about.

In general, the article is for team based multiplayer with fixed spawn points. Deathmatch or teamdeathmatch with random spawns is not what this article is about.

Small Tale

When I first played multiplayer games I started to think about why some levels are more fun to play than others. All of my first MP experiences were maps made by professional designers. I started to analyze them and I compared the good ones with the bad ones. When I started to spend more time in the MOD community with maps from fans, the most important fact of map design was proved: Gameplay beats everything! Some ugly looking action quake2 maps were the most played maps on the servers and the nicer looking maps were rarely played. I know that this sounds a little too easy but if you think seriously about the maps out there you will notice that most level designers care more about the aesthetics than the gameplay of their maps. If you're thinking about professional map design, the aesthetical quality of your maps is very important. However, if you don't care about gameplay you shouldn't start a professional career at all.

I have worked with a lot of different level designers, from absolute noobs and MOD mappers to professional designers and some who just thought that they're professional. A lot of them work without a real schematic system and if they created a good map, more often than not, it was down to good luck rather than skill.

Level Design Terminology

It might be silly to explain these terms to an experienced mapper or gamer but I have noticed that everyone has different associations with these terms. So I just want to explain my interpretation of these terms so we are on the same level of understanding.

CQB

Close Quarters Battle; Even closer than short range; normally lots of cover; ideal range for shotguns or submachine guns; scoped weapons are useless; this game-play supports fast movement and reflexes.

Short range

Similar to CQB but not so close; ideal range for shotguns or submachine guns; scoped weapons are still useless; supports fast movement and reflexes; maximum range to throw grenades.

Medium range

Ideal range for normal rifles; shotguns become useless and submachine guns become weaker; scoped weapons start to become effective; from now on only possible to fire grenades with a grenade launcher; reflexes and movement are still important but aiming becomes more difficult.

Long range

Snipers paradise; ideal range for all weapons with scopes; for weapons without scopes it's really hard to hit anything; normally only with a small amount of cover; you should have good aim instead of running/firing skills.

Stealth areas

Areas where silent/unnoticed/tactical movement gives you a big advantage; normally with lots of cover; several dark spots to hide. You can move through the whole area without being seen by a camping enemy.

Roamers

Players who prefer to be between the two; instead of real defense or assault; they need a lot of room and combinations of quick connections between the areas to react to the different game situations.

Rusher

People who just want to run through the whole map as quickly as possible; they want to reach the mission goal as fast as possible; surprise the enemy with speed/reflexes is their motto

Campers

Most hated kind of player except cheaters; you can find them in all realistic multiplayer games so you will have to learn to deal with them; they prefer to hide/stay in real nasty positions until an enemy runs into their line of sight; prefer short and CQB situations because then they don't need a lot aiming skill, natural enemy of the rusher

Snipers

Guys who prefer to run around in long/medium range areas with scoped weapons. It is a misconception that snipers are the same as campers because a smart sniper will change position after each shot, normally long range fights between snipers are more tactical, there are snipers who run around like rusher guys except obviously they avoid CQB/short range fights.

CTF

Gamemode: Just for the few unworldly people who never heard about Capture The Flag. Two teams have to protect their relevant flag while having to steal the flag from the opposition. They can only score if they bring the enemy's flag to their own one which has to be in its home position.

BOMB

Gamemode: One team attack and have to place one bomb at one of several spots which another team is guarding. They need time to place the explosives and until the bomb blows up (timer), the original defending team still has the chance to disarm it.

DOMINATION

Gamemode: I use several variations of this gamemode in this article. In general you have to control of one or more areas/spots which you have to protect. You score regarding the time you hold them.

VIP

Gamemode: One team has to escort a special player on their team to one or more specific point(s). The other team has to find and kill the VIP on his way to the rescue point(s).

Basic Strategy Balance

Introduction

The strategic plan behind every map is the key to a good map. These first deliberations will determine if the player can roam without real confusion. If the mission is basically balanced, then you will help yourself a lot because you will not have to make major alterations to the map at a later date. Everything you will read in this chapter is in the conceptual gameworld. Here we don't care about the positions of trees, houses or rocks. Stay in this basic world as long as possible and only continue with more detailed sketches when you are 100% sure that the basic strategy concept behind your map kicks ass!

The first basic Layout Settings

Setting the basic layout of your map is the first and most important step in level design, and one that is often overlooked. Just picture all the possible paths of the player as simple lines and you will begin see a basic geometric layout. Normally you can make a basic sketch for every gamemode. The sketches should contain only the most important facts and rules of that gamemode, nothing more.

Some explanations of the example sketches: The quality/accuracy of the sketches is very rough and basic and art skills are not important here, gameplay rules. If it looks symmetrical it should be assumed it is symmetrical. Based on these sketches I want to show several possibilities for the round and reinforcement game modes.

The first sketch is for a normal CTF game and not for a round based gamemode. The stars mark the spawn point and the point of the flag. These are

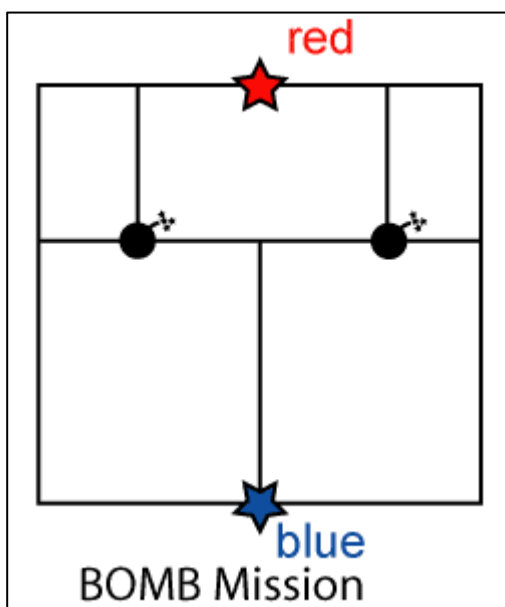

very simple example sketches and should only show the main intentions of these gamemodes, e.g. for CTF there should be three ways to every flag and the layout is usually symmetrical and balanced for both teams. The horizontal line between the three ways is the minimum amount of freedom you should include to switch between the routes.

The second sketch is for a standard BOMB mission. Team blue has to place a bomb at one of the bomb spots and then has to defend that area until it explodes. Team red has to prevent team blue from accomplishing its mission. The plan is for a round based gamemode. For the bomb mission we have two bomb places where team blue can place the bomb and every bomb site has three entrances. Team red is able to reach the spots faster because they have to defend these positions. This is the reason why it usually shouldn't be symmetrical for both teams.

Making it more complex

Now let's improve the basic sketches because every one of your maps shouldn't be like my first example. The following examples are just one of a million possibilities and you will design many alternatives.

We start to analyze the changed CTF mission. The basic intentions are still the same but the left and the right way have changed. The left side became more complex in the center. This should avoid strong concentrations of enemies in the middle defense positions. Even if it is easier to come through the middle part it is still hard to get directly to the opposite base. You can come with a large amount of fast and good players very close to the enemy's base but the 'last few meters' can be very hard. The right side is still unchanged in the middle area which might raise the danger in that area but as soon as you come close to the enemy's base you get more possibilities to react to the enemies defending strategies or to bluff the enemy on one side and switch quickly to another entrance.

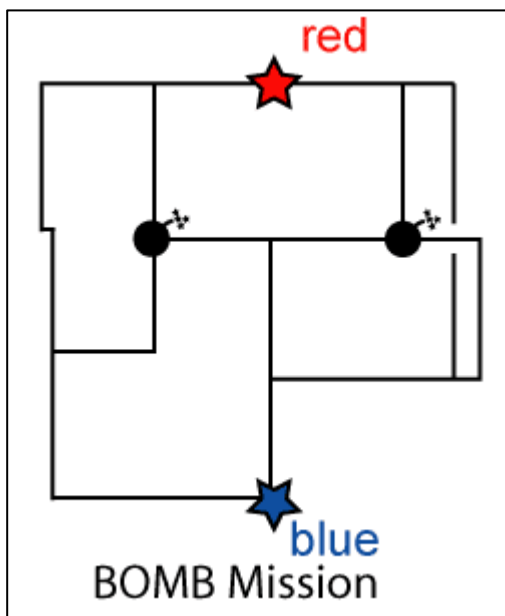
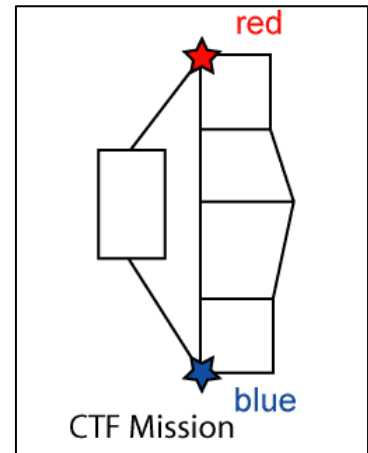

Now the bomb mission for the round based gameplay: the two main ways for team blue to reach the bomb spots still have the same length but they now come from different directions and give the player the possibility for a third way to get to the bomb spots to make it more interesting. On the left side team blue has a chance to take a longer and less flexible way but coming in from behind. For team red this way is less interesting because there is no direct way to the bomb spots. Remember that team red needs fast/short and good possibilities to switch between the two bomb spots at any time. At a minimum I would make two ways or one big way which they might come from as soon as team blue has placed the bomb. On the right side team blue has got a tunnel which leads them to the back entrance of the mission area. This way is shorter than the new way on the left side but in general a tunnel is more dangerous for attackers and has a higher risk.

These were easy examples but in this stage of development you should be thinking about the main battle areas in the middle and the mission areas of the different teams. A more complex middle area shouldn't have a lot of ways to the mission goals. On the other hand several good entrances to a mission spot shouldn't have very easy ways to reach them. It has to be balanced through the ways and between the ways itself. We will discuss later in this article how the size of the map should affect your basic design.

I imagine you already have enough of your own ideas and if not it really helps to analyze current well known maps to understand what I've explained above. Normally you shouldn't create extremely complex path systems because the player wants to learn his environment quickly and shouldn't be confused by too many different routes. Please don't think that you have to translate these geometric lines exactly in 3D! Of course you should change, for example, the angles of the corners, and the straight lines later, as you need it to be in your specific situations.

General Area Settings

After these two first steps you should bring your vision of the look/setting/environments into play by adding it to the basic sketch. Still a very rough sketch but it might help you to get a better feeling of what your map might look like.

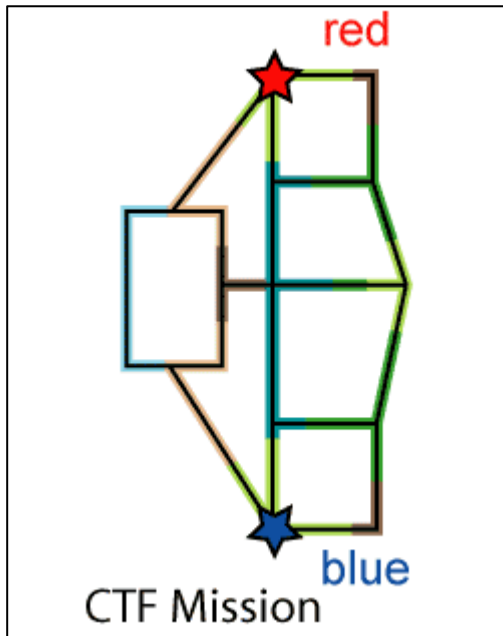

For the CTF mission I chose a jungle setting and thought of some different environments which I can use for the different ways and areas. The light blue is for a beach (ocean, river or lake), the bright brown is for a stony mountain area with few plants but with bigger rocks as hard cover, the dark brown are caves or tunnels. Dark blue green is for deep jungle with several big trees and a lot of sight cover. The dark green is for normal jungle and the bright one for grass. The environment layout is symmetrical but the combinations are always different especially in the middle area and the way to the base. These areas should have a lot of landmarks because the player should always know where he is and where he is going, it helps for orientation and is very important to the immediate feel of the map. The left will be long range, the middle way is close combat with a dangerous way over the grass to the base and the right way is middle range and stealth in the tunnel. Be sure that you implement different areas for the different

kind of players like normal roamer, stealth players, rusher, sniper and CQB freaks. Of course with some settings like on a ship you can't support snipers very well. This will be understandable for the player but if you make a big desert map without having some mid range areas it might confuse the players of that type because they will not find a location they are happy with. It is the same if you call your 45 horse power car a 'sports car' and then being surprised when people laugh at you or don't take you very seriously ;-).

Now take another look at the third bomb mission sketch and you will see that I have used the same system to allocate my environments. The mission areas have very different combinations of environments and the ways to these spots are different for each team. For the general setting I chose a harbor/urban environment. The dark blue is a small river with concrete walls around it, the bright blue is directly at the harbor, and the brown defines warehouse areas. For the urban part on the right side I chose a normal street (green), inside of houses (pink), sewer (dark red) and backyards (purple). It doesn't matter if you are a stealth CQB freak or rusher, now every bomb spot has the possibility to make you happy but you can still orientate yourself just by the different settings around you.

Sewers are normally something for stealth players (e.g. caves or dark back routes, warehouses, apartments, machine rooms, etc. for CQB freaks). On the other side, you can have open areas (e.g. streets, open fields or beaches for the sniper fans). Generally, every environment is for a specific kind of gameplay. Be sure that you mix it well and retain a balance

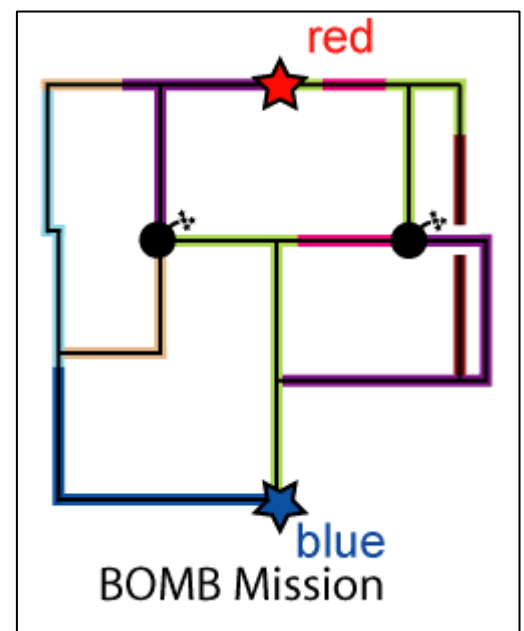

because after a long beach there shouldn't be suddenly a hard-core CQB area unless the route was already too easy and you need some kind of difficulty here for the player.

Assigning the environments is almost independent of the kind of game mode you have chosen, just be sure that it is very different. You find a lot of different sub-settings for the different kind of players and for orientation. I hope you are smart enough not to make every warehouse area identical to all the other warehouse areas in the levels. These areas should be different even if only subtle changes are made e.g. lighter/darker, empty/crammed, completely different kind of crates, more/less machines, no/some offices, decayed/clean, really tall/thin.

Special Talk about open Battlefields

I understand if people think that this kind of level design is strictly for that 'old fashioned' tunnel system or especially for 'Quake based games' but what about the open battlefields you have in "Battlefield 1942"? It is actually quite similar because even on big battlefields you are leading the players along main routes, but there is more freedom of movement in-between. Therefore, I would suggest that you first paint the main routes as plain surfaces, already with their specific environment. Then you should paint the tunnels and valleys, and the blocks between the main routes.

You can also see open fields as battle areas and mission areas which have no real connection between them. It is just one large area which is so huge that it already has strategic elements in place. I'll talk later in this article about battle and mission areas so don't get impatient.

Strategic Summary

It doesn't really matter how you make your sketches at this point, it is more important that you really think about the strategic game mechanic and the flow of your level before you start with more detailed ideas. Believe me; I saw enough sketches from other designers who already put every waterfall or tree in their very first sketch, even before they noticed that the gameplay in that level might be really unbalanced or boring. Of course, it is not wrong to think about where you want to put your waterfalls or other nice ideas for your level but, for the moment, keep your ideas where they are as you will use them later on.

The most important thing to remember when you are making a basic sketch is that it has to be balanced! An unbalanced map is always bad; especially if you are making non-symmetrical maps. If the strategy is balanced you are already on the safe side but it still might be a funny map if a few tactical elements are not 100% equal for each team.

Another thing I would really like to emphasize is the originality of your map layout. Try to develop your own ideas, be experimental, and always try to create something new and unique. Normally you have enough time at school or work, in a traffic jam or on the bus just to think about some new basic level layouts. If you are really stuck for ideas and you decide to copy an existing map then please at least be smart! Nobody really needs a Mongolian version of `de_dust` with just different textures and the same boring architecture. If you really want to copy `de_dust` then try to make it original in your own way e.g. change some tunnels to open areas (and inverse), replace level-limitation-walls with cliffs, improve the variation in the main battle spots, add a new stealth way, mirror the layout or certain parts of it, or better still, change everything!

Improvements With Tactical Elements

Introduction

So far I have been talking mainly about strategic elements, but the player also needs some really good tactical possibilities. The player doesn't necessarily see your strategic deliberations but he directly sees your tactical ones, so be sure that they are good and fresh.

After forming your basic plan, you can already build a very rough version of your map in your editor. It is a good idea to test your map by running around while timing how long it takes to get to different areas of the map. If you find that it takes you 2 minutes to run to the allocated battle zone and the other team takes only 30 seconds, then you should really change your strategy layout. Move the battle zone or slow down/speed up the players in certain areas so that everything works fine again. This will be explained in more depth later in the article; just never forget to test your map at an early stage with a clock.

Battle Areas

Introduction

Battle areas are the places where the two teams meet if they start running from their spawn points with the same speed. If you have a game where not every player has the same speed, you should think carefully about where to place your battle areas. You need to make them big enough so that; if the slowest player and the fastest one want to reach the field, the faster one should have an advantage (e.g. reaching a good sniper spot without any real danger or jumping into the alternative tunnel without seen by the enemy). Here, you can already see that tactical elements are really important to support the different kind of players you have. A large sniper area should normally have an alternative route inside for really fast scouts. Even a big CQB warehouse should have a longer hallway between the crates for some mid range fighting.

Basic Rules

Before we take a look at your example maps, we must learn some basic rules of battle areas. I'll try to explain the basic intention of these rules in small, understandable sketches, feel free to improve them and don't use so many crates like I'm doing it here. These sketches are solely for the intention of demonstrating these rules. The rest of the design might not really be perfect, but it's the intention that really matters. If I am talking about entrances, it is not always simply a doorway into a big room; it could also be a roof, a canyon, or a hill. It just depends on the situation.

1) *There should be always more than one entrance to a battle area for each team (or the only entrance should have enough cover in front so there are at least two possibilities to appear in the area).*

There is nothing more stupid than when the player knows that in 12,3sec the opponent player will come through that specific door. If the level design makes player movements too predictable, then it is a bad level design!

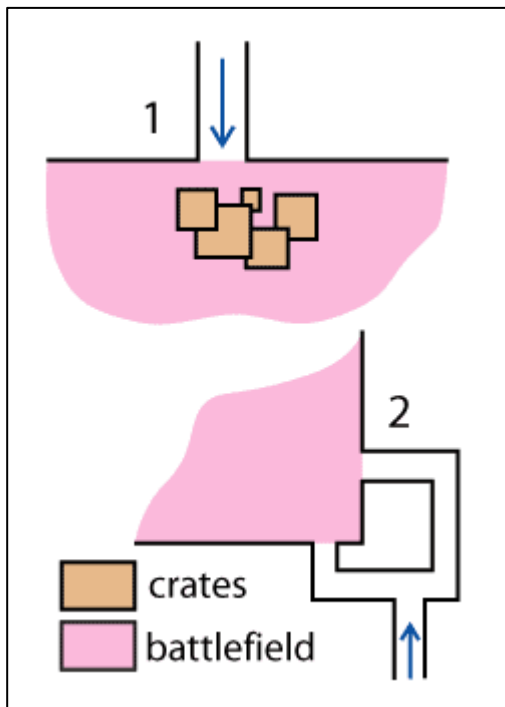

In the first situation I placed some crates in front of the entrance. Now the other player can either come around the right or the left side of the boxes, or perhaps he can even jump on the top of them and perform a surprise action. Of course, there is a mass of different possibilities to enhance it, not just two or three ways but especially with nice architecture.

The second possibility is similar but a little bit more confusing for the player. At the beginning he might think there are two completely different ways. Soon he will notice that both ways lead to the same result. Of course, this depends on the distance between the two entrances and the distance to the lurking enemy. For a sniper who is 150m away, it's quite a lot easier to protect these two entrances than for a rifleman who can only be 20m away. If you really only have two ways for each team to enter the battle area, it is always good if one of the enemies can never see both entrances clearly from an advanced position.

2) Campers should never have an easy life!

When you place your tactical elements, always take a look at where there might be typical camper positions. If you have such a situation, be sure that he can never see all entrances to the battle area, and that the opponent always has a fair chance to move around him and shoot him from behind. If you have an important door which a camper might hide behind, make a second door near the first one. If there is a good position to see both doors, place an object (e.g. a crate/pillar/bush) in front of one of the doors to obscure the camper's vision. Always remember that sniper positions might also make very good camper positions, so they should be treated the same way! If you want sniper positions in your field, every team should have a minimum of two, and they all should be able to see each other. A sniper position, in this case, is a single spot. If you have a big hill or a house with some windows for snipers, it is enough because you can never predict exactly where they will appear. The best way to defeat a sniper is with a counter-sniper. Both snipers should have more than one position to attack from, otherwise it might become boring and the only challenge is to reach the position as quickly as possible. At least one sniper position should be bad, and every sniper position should have a counter-sniper position. If one sniper position is too powerful, then it could easily become very frustrating

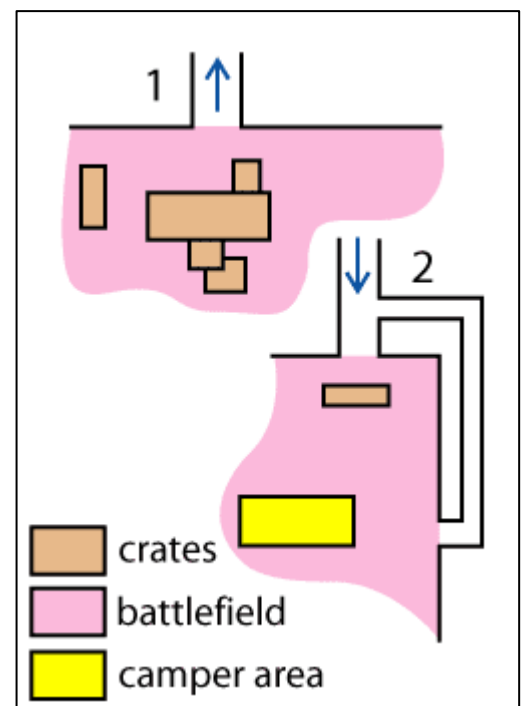

The first example is typical. The player wants to run out of the battle area but there is a nasty camper behind the crates. In this situation he might have some problems. The player is able to jump on the big crate in the middle or he can go around the big crate from the left and the right side. The left side has an additional way to appear from another situation. It is impossible for a

camper to hide next to the crates and protect himself from all areas of attack.

For the second situation I chose another well-known problem. A camper might be able to hide very well in the yellow field (bushes/rocks/etc.) and protect the north entrance. Even the small crate in front won't change a lot, but a simple walk around reduces the advantage of this camper area drastically, especially if the east entrance is on a higher level than the north one.

Another good solution to weaken campers is to give the players a chance to use their special equipment or to use the special features of your engine. For example, you have to cross a long tunnel and you know that there is someone with a sniper rifle at the end just waiting for you to jump down. Why not make it easy for the player to throw a flashbang inside or quickly run to the entrance of the tunnel into an alternative route which you can only reach with the help of a smoke grenade? Of course the smoke can also come out of a pipe or you can switch off the light, etc. It is the same with windows; a grid always looks nice but if it makes it too difficult to blow out the sniper with a grenade then it is bad for the gameplay.

In my sketches, I only work with easy elements like walls and crates. With more complex architecture and interesting terrain, you should find enough new situations to avoid the widespread camper problem. You will never prevent it completely but this will make it more fair and fun.

3) *Give the player enough tactical possibilities, make him unpredictable.*

If there is only one big cover in the middle of your area it's quite easy to know where your enemy might be. If you see a grenade falling next to your foot, it would be cool if the enemy doesn't always know that you have to come around a certain corner to find him. The player should be able to move less predictably through the field. It is quite boring to know that in every round/match, very similar situations will happen.

If your area is just flat without any higher levels, it doesn't just look boring, it is also bad for cool tactics and the enemies normally always know at which height is/are your head/nuts. A good terrain and architecture with different floors is really a blessing! You can prevent a lot of complex cover placement with some hills and valleys. Firefights between levels of different height are always fun in urban environments, especially if you can switch them quickly. Terrain levels might give a fresh variation of different views (e.g. from a high hill you can see behind the rocks where you presume a nasty camper is hiding, or down in the valleys you can see below the car and shoot at the feet of enemies who might hide behind it). You really have to check all different kinds of positions and their tactical possibilities and be sure that everything is fun & balanced!

Use alternative kinds of cover; soft cover (e.g. bushes, grass), half cover (e.g. small boxes, trees), and full cover (e.g. big rocks, house). For example, if you want to prevent the sniper in the upper window seeing the roof on the right side, just place a tree in-between. Now only lucky hits and covering fire through the tree might be a success and in a lower level, the tree trunk is a nice half cover. If you want one team to be able to pass easily from one big cover to another, just place several bushes there. However, as soon as they are spotted, they might have a real big problem. Such elements can not only be tactical and funny for the stealth player, they can also be exciting too. Sadly, it is true that a lot of level designers forget to include these soft cover elements (bushes etc).

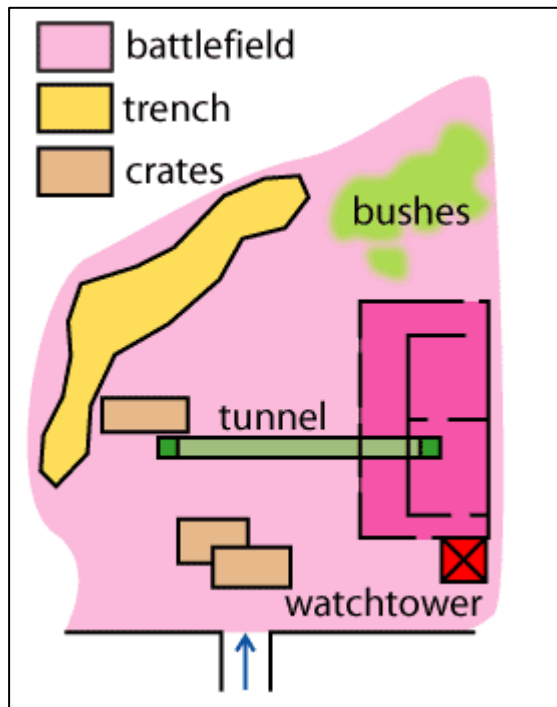

This is just a simple example of tactical variations. The player is coming out of the south entrance. He can choose between the left and the right way around the crates (full cover), to reach the other boxes. Behind this crate he has four different possibilities: the two different sides of the box (normal), the tunnel which leads into the house (surprise change, higher level) or jumping into the trench to sneak forward (stealth way and higher level). If he chooses the right way at the beginning he can go into the house (CQB and windows are half covers), in the watch tower (sniper point) or he can climb on the roof of the house (high level) with a few air-conditioning ducts (half cover). At the end of the house he has some bushes (soft cover) which might help him to sneak forward but won't help him if he is on the roof.

4) *Include special ways for special players.*

No, I don't want to tell you again that you should include stealth and rush ways. Real special ways should support people who like to take extreme risks or absurd ways to really surpass the enemy. I wouldn't say that this is a must to have in every battle area, but a few in your level would really increase the fun factor. I'm thinking about hard jump combinations (e.g. to reach another floor which you can use to walk around your enemy, or to reach the upper part of a tree to hide inside). Other special ways would be secret and hard to find; climbing tracts or areas which you can only reach together with a teammate (i.e. a ladder). I don't think I have to make a special sketch for this last rule, just don't forget the pro and hard-core players might really thank you for such small ideas.

Imagine a main battle area like a large room which gives the player a lot of different possibilities to cross it. If you add some more, smaller routes to improve the tactical possibilities in your battlefield, then treat them the same as you would the strategic routes. For example, the short way is fast but more dangerous and the longer/more difficult one could make it easier to avoid campers. There should be never an ultimate route (or routes) or an ultimate position. Everything must have advantages and disadvantages depending on the type of player! Keep this in mind and try to follow these rules as closely as possible, and the players will have some really exciting firefights in your level.

Don't be afraid to force the players to move fast on some ways or to stop them if you have to. If you don't want the players to cross the square very quickly, just place the only good cover at the border (in the middle there is some kind of 'death zone' every smart player will avoid). If you want the player to move a little bit faster, just make a bigger hallway with no cover and you'll see that every clever guy starts running here. Okay, you don't always need to make it so hard but sometimes you have to, especially if you have moving missiongoals like VIPs or flag carriers. I'll talk more about this topic later.

CTF Example

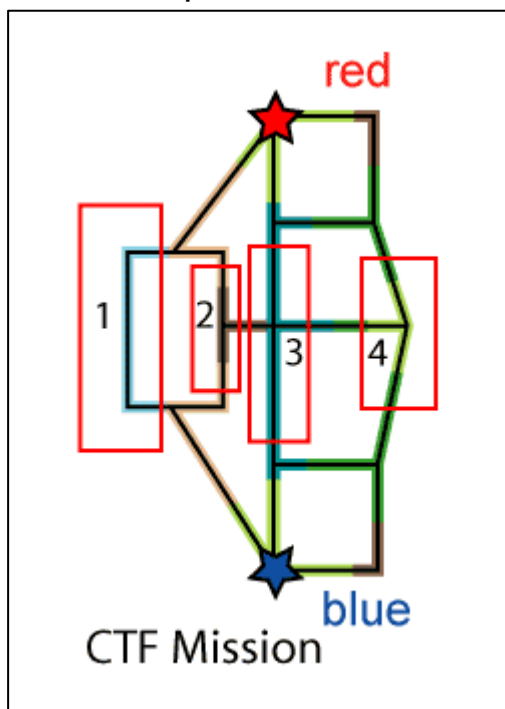

Okay let's start talking about the main battle areas of your CTF example map. Normally, you don't have to draw the areas in your sketch. I guess you are smart enough to imagine it yourself. The following explanations about the areas are just examples to help you get the right idea about how to make it in your own map. The size of the areas have nothing to do with the sight/fight range inside, they just mark them.

1) *Beach, long range, bright area, less cover*

At the beginning the player can appear at a lot of different spots behind some rocks and bushes. The large part in the middle beach has much less cover and you need some backup support and cover from behind to reach the other side. If you take the high risk option, you can swim to a bigger rock on the left side in the middle. There, you can climb up and you have a greater advantage against the opposing forces. Imagine some fast-moving scouts and the player will have some real thrilling sniper battles here. It is a

high risk to choose that way if you want to flee with the enemy's flag, but this can be your advantage because nobody would expect it. "No risk no fun"

2) *Cave & rocks, short range & CQB, dark light, a lot of hard cover*

This is completely the opposite of #1. The dark light, the short range & CQB drastically reduce the advantage of a scoped weapon. There are so many rocks and bushes that two really lucky teams can pass without even seeing each other. At the beginning of the area there is less cover so these places are more dangerous. But you can start running over these 'dead zones' from a minimum of two positions to avoid too powerful camper positions. The middle part is a little bit higher than the entrances to that area. This is to avoid sniping possibilities for too long a distance between the rocks/bushes. This is a very good route to choose if you have the opposing flag because the enemy might lose you inside.

3) *Deep jungle & ruins, medium range & short range, medium light, some sight cover*

Because this will be the main battle area, the number of tactical possibilities in this large, long field should be very high. I chose to add ruins because it increases the tactical variations, and because urban elements and nature dominate the environment which helps the orientation. Tall trees and ruins provide the hard and full cover here. A tunnel and a small creek around the decayed buildings increase the number of tactical variations and make the area more interesting for stealth players. Even if you have some sight cover, there should always be some small fields without a lot of cover. It would be bad if, in the main battle zone, two teams could pass each other while running into the enemy's base without seeing each other. In the main battle zone, the players should really have a fair chance to find each other and have a lot of exciting firefights. The sight cover and the medium light should increase the thrill factor but it shouldn't become too dominating.

3) *Medium hill, medium range, good light, mainly hard cover with a few sight cover*

The whole battle zone is on the top of a small hill, so the opposing players can't see each other until they come closer. Due to the mountain setting there are a lot of rocks and just a few bushes. The gameplay will be very basic: to run from stone to stone while fighting with the enemy. The area is medium-dangerous or easy and not for the special kind of player. A few more bushes on the right side or a small ruin exactly in the middle would make the area more tactically interesting. Then the fastest team can gain control of the ruin and have a good position to fight against its enemies. Of course the slower team should have a fair chance to blow out the snipers/campers in the ruin e.g. with several spots where they appear, more sight cover at the beginning, or some really good countersniper positions.

BOMB Mission Example

The bomb mission has one more battle zone but in general they are much smaller than the battlezones of the CTF example. If the strategic possibilities are higher then the battle zones are getting smaller. This is a very simple rule and if you don't believe it just imagine a BOMB mission with 10 battlezone where every one is as big as the beach zone in the CTF example. I guess a majority of people would say: "Whoa damn big map but I thought the intention of the designer was to create some cool fights/matches instead of a sight seeing tour through North America". Of course this depends on the expected number of players for your map. I'll explain this in more depth later so let's continue talking about the battlezones of the BOMB mission example.

1) *Harbor next to the sea, medium/short range, good light with some dark spots, mainly hard cover*

In the normal harbor setting we can use what I like to call the 'mapper's crate disease". Please try to place your cover objects only where they fit. If you are using crates and boxes, they should be next to warehouses, storage areas, market places or harbors. If you see whole Arabian/Italian cities covered by wooden boxes or islands/deserts overflowed by crates then it is normally a level designer with a low poly engine or someone without enough imagination. Hey you can blame me, too, but I got sick of too many crates and learned to avoid them. Just find other cool cover elements especially architecture. You won't believe me but recreating can be done WITHOUT using crates all the time.

Never mind, now we are in a harbor area and we can use a mass of containers here. The battle zone shouldn't be linear. The player should have a lot of merged/linked routes that he can take e.g. jump into the water (slow but very stealthy) move between the crates (fast but might be risky because the enemy appears at a very short range) or through some nearby warehouses (darkness is stealthy but risky). To avoid a "liaison" with the enemies should be almost impossible but as soon as the fight starts the game-flow shouldn't slow down due to the many small tactical possibilities. Additionally, it's always cool to give the player some extraordinary playgrounds e.g. freighters, cranes or ferries. If you have the possibility to include such objects, then they should be part of the gameplay, e.g. the crane as a wonderful sniper-position, the top of a freighter as an alternative way, or a decayed, resting ferry as a connection between two sides of the water. It depends on the harbor setting, but a few plants are never wrong, except if it's a real high-tech/new industrial harbor next to a nuclear power station or chemical waste depot.

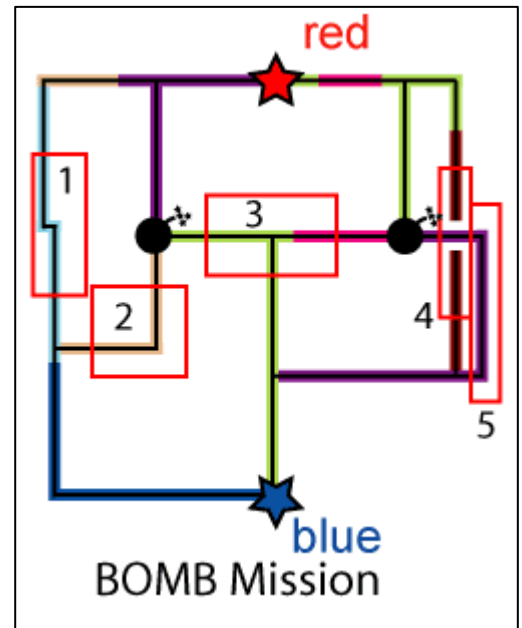

2) Warehouse, short/CQB range, dark/medium light, mainly hard cover

One of the smaller warehouses in area #1 has a big entrance to some real storage areas. This directly leads to the left mission area. I guess for some of the level designers out there this might be the best place because they can place even more crates ;). In big storages you can easily add different high levels which might cause really cool fights between the metal walkways and the wooden boxes. Be sure that there is a real advantage to use a higher floor because normally it's difficult to find a safe way down again. Light can be a really powerful game-play factor in these areas. Fast and easy routes are illuminated by moonlight through big windows in the ceiling or artificial light in the lower levels. If you balance the upper and the lower levels in the right way (avoid too powerful sniper-positions, give the player a little bit of freedom to roam through the big rooms), you can expect some enjoyable firefights in here.

3) Street/indoor, long/medium/short/CQB range, good/medium light, mainly hard cover with a few soft cover

To make a long street both fun to play and balanced is very difficult. Normally, long streets cause boring sniper battles if the street is narrow and doesn't have a mass of cover, (e.g. cars, doorframes, trees, etc.) or alternative ways through apartments/backyards/gardens or over roofs and balconies. Such urban battlefields are normally not in harmony with the engine used. Balance, fun and performance are the understandable reason why most level designers would choose many more corners instead of a mainly straight street. If you still want cool street fights like in the movie "Heat", plan it seriously and think carefully about the snipers and campers. Make sure that the attackers have a fair chance to reach their mission areas. Shortcuts or stealthy ways through indoor areas are a good solution to this problem. Snipers are normally useless in a CQB situation and if you have some more small ways than usual, campers avoid camping in alternative routes. In the game world, you can compare it with a sniper battle in a long hallway which is rarely always great fun. Sniper fights, especially in urban areas, should be in wider spaces rather than narrow ones.

So let's place a few low poly cars and several trees on both sides. Additionally, the entrances to the houses provide really good cover. Several stairs and cellar entrances increase the amount of normal cover on the street. Now we add some places to make the attacker more unpredictable, like some balconies/windows or shortcuts through parks/gardens/backyards. The defenders shouldn't have a mass of cover at the end of the street. It is better if the defenders have to move around a lot and choose different cover objects further away to be a real danger to the attacking troops. Defending positions should never be so powerful as to see the whole street. Use the trees as sight cover to force the defenders to occupy a minimum of two or three positions in order to watch the whole street or battlefield. Of course, the enemy must also have some nice counter-positions.

4) Sewer, medium/short range, dark/medium light, a few hard cover

Normally if people think about tunnels in multiplayer maps, they think about nasty guys who wait at the end of the duct with a scope until an enemy walks around the corner. So if you really want to make a longer sewer system, try some of the following ideas: don't make the tunnels too narrow, the background of the corner for the attackers should be darker, the corners where the defenders might wait should have a bright background, try to make more than one tunnel (or other alternative ways e.g. through cellars or let the players go up and down through a backyard), avoid really long tunnels and think about the special equipment in your game, especially all kinds of grenades! For the players, tunnels normally always look the same and they might lose the orientation very quickly. So add, for example, some obvious graffiti, unique trash constructions

(e.g. toilet paper which points into specific directions, newspapers always lie on one side of the sewer, etc.) or, for the attacker, the tunnel always goes upwards.

5) *Backyard, medium/short range, medium light, mainly hardcover*

A typical backyard is the place where the criminals in an ordinary police series nearly always run away from the cops, climb over a mass of fences and walls and finally fall over some plastic trash bags. I think this already explains the key elements that make a typical backyard. You need a lot of up and down in combination with fences and a lot of small cover like garbage bags/boxes. If the setting fits then even some decayed ruins, pipes or balconies increase the amount of possibilities for the level designer here. Just follow the basic rules, make some cool positions and always add another counterposition so the enemies can force the opponent to keep moving. Be sure that the backyard has its typical lighting, make it really wet & dirty, and avoid placing too many crates.

Mission areas

Introduction

I guess you guys still don't have enough about battle zones but now we have to talk about something new. Mission areas are similar to battle areas except for two things: they are more critical/important and normally one team don't just walk/run/'bunny hop' through it, they are actually doing something there. The mission area is the zone around the flag in CTF, the place of the hostages in HOSTAGE RESCUE, the bomb spots in the BOMB mode, etc. All the time one team has to do something in a map, aside from 'only kill enemies' (DM/TDM). Because of this, they need some special attention. In general, you might say: "It doesn't matter what happens in the whole match as long as the two teams come together in the mission areas". I wouldn't agree with this because the map needs a high fun factor across the whole map. On the other hand, it is true that in the end the two teams should at least meet in the mission areas.

Normally, one team is defending and the other team is attacking or every team has to attack/defend. If only one team has to defend, it's harder for the attackers. If they have to attack and defend, it assumes some basic allocation of available work in the team like roamers, defenders or rushers. Think about the different roles of the different teams before you start building your mission areas. A stupid example would be a building without any entrance, absolutely great to defend but kind a dumb to attack.

If you compare the walk of an attacker through a map with the escalation of a classic drama, then the mission area is the climax. The adrenaline of the player has to pump through his veins if he is 10m away from the flag, he has to sweat like a pig while he is placing the bomb or has to collapse after he brought the VIP to the rescue point with 1% health. Mission areas have to be exciting and risky but never unfair! "No risk no fun!"

Basic Rules

Like for the battle zones, I have set out some basic rules for the mission areas and their placement. These rules can be very different and are strongly affected by the game mode you use. So please read them carefully and only use the ones which might fit with the mission goals of your level.

1) *The difficulty of the mission area depends on the time the attacking team has to stay there.*

In the standard CTF mode you just have to grab the flag and continue running to your home base. Normally you only have to stay in the mission zone for a few seconds but, during the last time mission, objectives become increasingly difficult and more tactical. This means the designers have to change their old design opinions. If you lose 90% of your teammates & ammo just to reach the DOMINATION point, and you have to hold it for the next 10 minutes against a superiority of 10:1 without any good defending positions, something is obviously wrong. You have three possibilities to solve that problem. The first one is to make it really easy for the attacking team to reach the spot but then make it hard as hell to hold it. If the defenders have no real defending positions then it is obvious that the original attackers will find it difficult to protect their mission spot.

The opposite would be that it is really hard to get control of the area but then it's quite easy to hold it. It is always hard to attack a well guarded fortress but if your team was able to do it, then why shouldn't the old defenders have a tough run against it as well?

The third solution is to make the difficulty of the attack and the subsequent control almost balanced. Of course, this sounds like the best solution but it is also the hardest to achieve. I suggest that you should try to make your own mix and don't use too extreme situations.

2) *The difficulty of the mission area depends on the number of possible successful strikes from the attacking team.*

Okay, it sounds weird but just imagine a CTF match where my 85 year old grandmother can easily defend the base for 4 hours against 20 hard-core, bloodthirsty, professional Quake players. It might seem ridiculous and frustrating but, believe me, something might have gone seriously wrong with the design of the mission area.

In a CTF map, for example, there should be a fair chance that a good run against the opponent's base is a success. This doesn't mean that every time you walk to the enemy's flag you can grab it and move back. Normally, defending something is easier than attacking it. This is the reason why not every assault should be a success. A good tactic and a little bit luck should be the key for a successful strike and the level designer should give the teams a fair chance to do this.

Remember: "The best team should always win!"

Now you can say that in a real mission based map (e.g. with a BOMB objective) the challenge for the attacking team is always harder than for the defending one. In my opinion, in a round based game with clear attacker and defender roles for the teams, the ratio should be something around 2:3 or even 1:2. If every team has to attack and defend, the ratio should be of course equal like in CTF or DOMINATION.

3) *If the defender team has more than one mission area, they have to stay close together.*

Normally, if the defenders have more than one point to protect they have to split the team. The attackers can stay together and, if the skills between all of the people on the server are about equal, the attackers can win against the outnumbered defenders. So the other teammates have to run to the other mission area and try to rescue whatever they can.

Now imagine a BOMB mission where the bomb timer is 20sec and the fastest player need 40sec to run/jump/bunny from one bomb spot to the other one (and we shouldn't forget the disarming time). As I already mentioned earlier in this article, always run around in your map with a stop watch. Take care to look at the routes between the mission areas.

For example, if the bomb time is 60sec and the disarming time is 20sec, then the minimum two ways between the mission spots shouldn't be longer than 10-20sec. You should always give

defending team some extra time to fight against the original attacking team, depending how hard it is to reach the bomb.

4) A defender should never see all of the entrances to the mission area from one good position; keep the hot spots free from campers.

This automatically means that every mission spot has a minimum of two entrances. Actually, there is no problem if the camper decides to keep all entrances in his field of view, as long as he stands in the middle of a big open space. This important rule is for the defenders and maybe for the attackers, too, which depends on the game mode. If the attackers have to stay in the zone for a few seconds/minutes, they quickly become campers too. This is absolutely normal but just don't make it too easy for them.

Just imagine a hill with a mass of sight cover next to a mission spot where the attacker first has to run 30m over an open field. At least, you have no real fun checking all of the thousand possible sniper positions whilst making sure that you reach the hot area alive. The argument that mission areas should be really challenging is okay but it shouldn't be frustrating!

If you have a lot of hard cover around your defended objective (e.g. crates/pillars/rocks), make sure that the camper can never hide in one position where he can see all entrances. There should always be one side open which he can't protect when he is watching another possible route to the mission spot.

5) More mission areas for the defending team automatically means higher difficulty for the attacking team.

I guess that is very obvious, as soon as the defenders have to take care of more than one position they have a big disadvantage and need a small bonus (or the attackers a small disadvantage).

Just imagine a team which has to protect five different bomb spots or a very big DOMINATION area. They should have an easy job defending the area(s). An unpredictable enemy is always the most dangerous one because they have to encounter something equally challenging (e.g. a fast connection for the defenders between the objectives with a very good fortification). Now the protectors have to move a lot but as soon as they detect the attackers, they can beat them easily. This means the tactics/strategies of the assault team have to come behind enemy lines, unseen, instead of playing Rambo.

6) The mission goal has to be absolutely obvious in the area!

Make absolutely sure that the mission spot is very easy to detect. For CTF, this is more or less a minor problem because a flag is normally very easy to spot, except if you hide it deep down in a dark pit. Designers for a BOMB mission, for example, should be much more careful. If the player reaches the large mission area, which is a big warehouse full of wooden crates, and he knows that he has to blow up the brown crate with the drugs, it might cause frustration. Make the drug box green, with special bright light around it, a big red cross on the ground or place some unique and obvious objects around it. Every noob player which enters the warehouse must say: "Hey these single green crates in the middle of the bright room, with the red flags around and with all the red arrows pointing at it must be my mission objective." Okay, this might be a little bit extreme in a realistic setting but I think you get the point.

Moving Mission areas

You can forget most of the text I wrote in the previous chapter if you have a level with a moving mission objective like a VIP or train which one team has to protect and the other team to kill or destroy. There are normally two kind of moving mission objectives. A player controlled character/vehicle and a scripted object which always uses the same route.

Firstly, take a look at similar VIP game modes. You should find a minimum of two rescue points or one bigger area; otherwise the defending team would just heavily camp around one spot instead of roaming/moving around. Calculate the areas where the two teams encounter each other for the first time. These battle zones have to be quite complex or there has to be a high number of different, smaller battle zones. All of these battlezones need at least one alternative way out besides the obvious short way to the rescue points. As soon as the defending team knows where to find the VIP, they will try to intercept him on his way to the next rescue point. If it is absolutely obvious which route will be taken by the VIP, it is too easy for the defenders and not really much fun. There still should be some kind of exciting challenge after the first encounter. When the defending team has no real clue which will be the chosen rescue point, they have to roam around again and hope that they get the right one. Good team play is the key to success here, for both teams.

The second possibility would be an object which moves on a scripted route. One team must try to defend the train/truck/ship until it arrives at a certain area and the other team will attack it and try to foil the opponent's plan. As soon as the two teams see each other for the first time, a long battle zone begins. Along the way there are usually several small defending positions and main battle zones. Around these spots, the fights are particularly hard and between them, fights are more infrequent. Because the objective is very predictable, there should be several alternative ways for fast guys to attack these defending positions from the side. If the defending team has to do small missions at these hot spots, treat them like normal mission areas.

Take care about snipers and campers as I have already explained. The rescue points, in particular, are very critical. Some positions that are too powerful can destroy the whole fun of roaming and searching for the VIP in the areas before. Everyone would just stay next to the extraction spots if it is that easy to protect them.

CTF Example

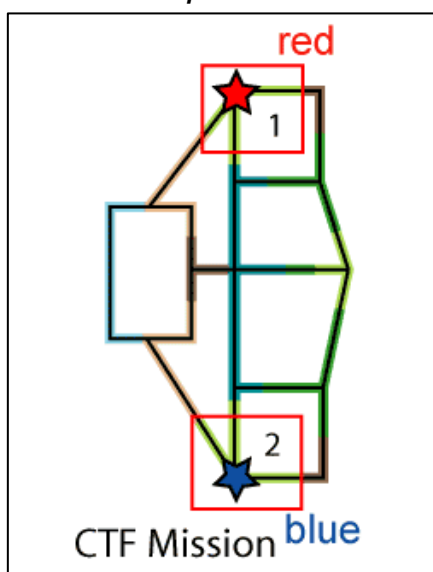

For the CTF example, both mission areas have to be similar so I only need to explain one of them. The area starts shortly after deep jungle in the middle, after the cave, and after the rock/mountain area. The whole area has a 'military base'-setting with some small huts, tents, bunkers, and watchtowers etc. The cave exit is already very easy to defend because it is quite small compared to the two canyon entrances. So it doesn't have any special defending constructions unlike the main/short way through the middle. This route is the fastest one and, because of this, the defending positions here have to be the strongest ones. Of course, it should not be impossible to attack, but some obvious bunkers, sandbags, etc. are definitely okay to slow down the enemy here. One watchtower has a main sniper position where you can just about see the cave entrance and most of the way down the middle. He can't see the last entrance because

there are several trees as sightcover on that side. It might be a good sniper spot but everyone knows that the watchtower is there and the sniper has no real possibilities to hide himself very well. The way from the beach is one of the longer ways to the base but, because the sniper tower can't see it, there should be a few weaker special defending positions.

The flag itself is not on a very big open place. It has some huts around which have no windows so the campers inside the buildings cannot protect the area to all sides. The players inside the watchtower can see the flag from above but if you don't kill the guy up there until you reach the flag it's your own fault. Around the mission area, sight cover (e.g. bushes or long grass) should be rare otherwise they might become favorite spots for campers.

BOMB Mission Example

Of course we already know two mission areas for the BOMB example. Let's say the attacker's team has to blow up some special crates with electricity for SCUD rockets, whatever, just something easy to detect.

At spot #1 we have a warehouse (brown), a street (green) and a backyard (purple). For the attackers, the fastest and easiest way is obviously the street. So the defenders have several very good defending positions behind cars, inside shops and windows to make it very hard for the attackers to come closer. Especially high defending positions are very good because attackers have problems finding good cover behind cars or other low objects. Several sniper positions should make the defending sharp-shooters more unpredictable. Remember that the defending team might start an assault in the back of the attackers force if they come from spot #2 and this shouldn't always be a massacre. The warehouse area should have less good defending positions because CQB, stealth, and short range battles through the warehouse are normally hard enough. The different high levels in the warehouse create different ways out of the mission area. From the upper ones it shouldn't be possible to go down very quickly but these are still very good positions to support the rest of the attacker's squad and to surprise your enemy. The backyard area is normally a very rare route of the attackers but some stealth/scout players might give it a try and should have a reward for the long and risky walk.

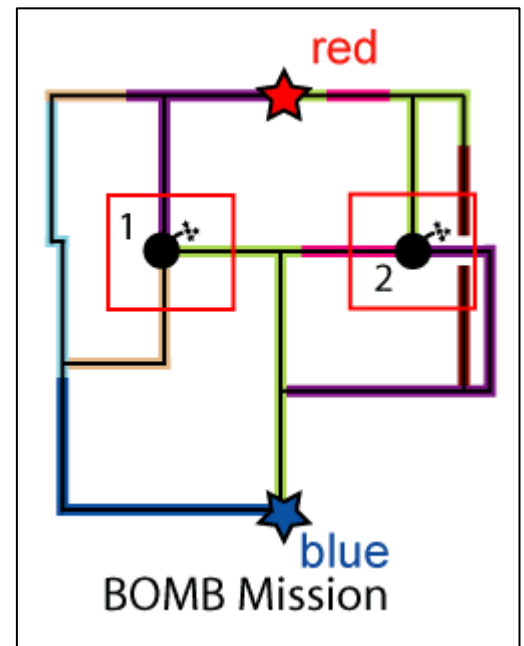

Spot #2 is a less open space than spot #1 because on the left side it has a CQB indoor section and, on the right side, a backyard part. Only in the direction of the defender spawn point do we have a more or less long/medium range section. So the majority of areas surrounding the mission spot # 2 are CQB and short range. This will mean that it might be harder for the attackers but they can appear very quickly very close to the bombing area. It is definitely more of a stealth and tactical challenge for the attackers to reach it. The indoor part could be something like a decayed flat with all the nice possibilities you can have in such an environment. Broken holes in the wall, kitchen, furniture, and several alternative ways should spice it up to a high thrill factor. Lighting here shouldn't be very dark; especially the corners should be bright enough so that no campers can hide here. In general there must always be two ways for the attackers to enter the room or another way around the room; otherwise campers have a huge advantage in this close battle area. The hard part for the attackers here should be to enter the house because it is still a very short and quick way. Several open windows and doors give the defenders a lot of possibilities to

appear, and they can still attack from spot #1. The backyard part should have several different high levels because the houses are very close together. Jumping over bigger metal trash bins, climbing up on balconies or a small shortcut in a cellar is really the minimum if you want to make this section fun. Light should be gloomy but definitely not too dark because it is a very tight area. It is okay if the middle of the backyard is a little bit darker, or there are some spots which are really dark, as long as the background from both sides is bright enough that you can see the shape of the player. The third possible way is the complete opposite of what the attacker had before. He is coming out of a gloomy/creepy tunnel in a medium and long range section. This won't be very easy for the attacker and, additionally, it is a very long way compared to the other ones. So it should be much easier for the attackers if they choose this way, otherwise nobody will take this way and building it was just a waste of time.

Movement Modifiers

Now I just want to talk a little bit about different situations which the player can pass and what you have to take care about. Of course, un-climbable walls, pillars or containers are movement modifiers, too, but I already talked about them at length and, in the next part, I would like to concentrate on typical passable sections.

Small hills or stairs

Here I mean smaller situations where a passable section blocks the view between two players (e.g. longer stairs inside a building or a small hill which is just a little bit higher than a player). They are quite common in levels and are a good solution if you need cover but it shouldn't really slow down the game flow, and the action between different high levels is much cooler than just on a flat ground. Due to its small distance, there is no real disadvantage for the player who has the lower position unless the enemy can see his legs before he can shoot back. Such situations can be very frustrating on main ways so please try to avoid them as much as possible. In houses, or on more sneaky alternative routes, they are more or less allowed but not really welcome. If you have serious problems with such a passage, create some good possibilities to throw grenades (especially flashbangs) or build a window next to it where you can see the nasty camper position in his full beauty.

Bigger uphill or downhill sections

If the high level is not very big just treat them gameplay-wise like flat ground. Especially outdoor maps should never be just flat because it looks/feels unnatural and boring. In my opinion, even bigger streets or places should never be 100% flat; small changes really create a completely different feeling. As soon as the height differences and distances become bigger, and the player really has to look up or down for a longer time, it can quickly become such a 'D-day feeling'. I think that in general, it is harder to defend/assault from a low position against an elevated position. In this case, good cover and possibly alternative ways or specials are necessary. On the other hand, a lot of people forget the sight factor in such a situation. If you look downhill it is normally harder to spot a player than if the enemy is at the top of the hill with the sky in the background. Of course, taking into account the usual camouflage factor of your game. If you have just red T-shirts versus blue T-shirts, the last point is less important.

Jumping passages

They can be used to spice up your level but please don't use them too much because jumping in a FPS is always a mess. Jumping up some crates or rocks is no real big deal but jumping from one house to another one, especially if the jump is not very easy, can quickly become very frustrating for the majority of players. On the other hand, hard-core games really like such

passages so it can be cool to have a few less obvious situations like these in your levels which make the good gamers happy. There are two things you should always remember if you are going to have the player jump somewhere. The first point is that you normally only look in the direction where you want to jump. On flat ground it is no big deal to strafe or to walk backwards but if you jump you normally don't have a lot of time to look around and search for enemies. So be careful with longer and harder jumping parts in hot areas. The second point is sound. If the player wants to pass such a part in your level he is normally making specific jump sounds which can be located by better players very easily. Try to be sure that after the passage there is a little bit of cover regarding its danger level so it doesn't become an absolute death zone all at once.

Doors and holes

Such situations are very common in multiplayer levels but as soon as they are in battle areas without alternative routes they become bottlenecks. The size of them should normally regard the amount of people that pass this section and its environment. For example, if the main way into a warehouse battle zone goes through a door, it should be more like a gate instead of a thin scratch in the wall. However, nobody will really complain if the sneaky alternative route leads through a normal door into a common house. Sometimes they very quickly become death zones if they are very small and lead directly into a hot battle area or mission area, especially without useful cover behind it. If there is absolutely no real solution (e.g. due to a performance reason), then the minimum is some bushes as sight cover against campers from the other team.

Doors which you first have to open are always elements which slow down your game flow and should only be used due to performance reasons or as a tactical element. Personally, I am not a big fan of usable doors in multiplayer maps because I always try to speed up the gameplay. It is rare that I really want to slow down my play speed unless I notice that one of the routes is too fast or that one team needs a disadvantage in one area.

Small tunnels and air vents

Every time the player has to crouch or go prone he is weak. He cannot react very quickly (e.g. running to cover or turning around if he is prone). So place such situations carefully. Normally, a small hole is not a big deal except if it is in view of an enemy defending a position. If the player has to crouch or prone for a longer time (e.g. in an air vent), in most cases it is a trap as soon as he is noticed. The enemy can easily throw a grenade in the tunnel or shoot through the thin walls. Surviving such a section should be rewarded (e.g. coming out behind the enemy's lines or with a very good position to stalk opponents without a lot of risk). The risk factor of entering and exiting should depend on the advantage the player will get.

Ladders

They are a quick and a very easy method to connect two different high levels. Ladders have the huge advantage, for the level designer, in that you don't need a lot of space. On the flip side, being on a ladder is a disadvantage in most realistic games because you can't shoot. This is the reason why you shouldn't often place them in hot battle areas, unless the player can reach a very good position (e.g. a sniper tower or a sneaky shortcut). Additionally, they slow down the gameflow so you should think carefully about whether this is what you want in this specific situation. Normally you should try to solve it with stairs if it is easily possible.

Hallways or what happened between the Areas

I think you have probably noticed that I am always talking about zones and areas but rarely about what happens between them. In general, you should try to keep the passages between battle-

mission areas very short because they can be bottlenecks and just walking isn't as fun as fighting. The width should always regard the amount of players that will pass the section. A main route should be much bigger and maybe have some small alternative routes nearby and inside the connection and also a sneaky, alternative route. There are three typical kinds of connections depending whether you want to slow down, speed up, or just want to keep the game flow neutral. The first way is to slow down the game in hallways or canyons. If you want to achieve such a situation, do not create alternative ways, just a normal, more or less wide hallway or canyon. Then the cover elements like rocks or pillars should be placed at the sides without an opportunity to walk around. As soon as players from two teams meet each other here, they normally take cover behind your objects. They have to stop unless they go in the middle again and start fighting. At least this slows down the gameplay and makes this section more dangerous. You shouldn't use such a type in routes which are already very long because these ways are more often used by faster players and they don't like it if they are suddenly in a slow gameplay section. The second way is to keep the player moving and therefore speed up the gameflow. One possibility is to create small alternative ways or shortcuts very nearby and with several connections to the main route. For example, a cellar which leads parallel to the road or a second route over balconies while the rest of the players keep running on the street. The second possibility to increase the flow is intelligent cover placement. If the cover (e.g. trees, walls, pillars) is in the middle or built so that you can continue walking in the original direction, then you can keep on moving if you see an enemy. Just switch the side of the wall and for a few seconds the enemy can't see you because you have changed your position. At the end, it doesn't really matter exactly what you build as long as both sides have the opportunity to change their positions erratically as soon as they see each other. It makes the fights between them more interesting, and the areas more fun. If you build it well, the player won't really notice the difference between the areas and the connections and this is the way it should be.

The last way is actually the worst one and should be used carefully. It is simply a hallway without any alternative routes or really good cover (e.g. a normal, boring hallway which goes around a corner). No team has cover and the fights are normally very quick. They are very simple, less interesting and not a lot of fun. You can use these for less important connections or just keep them very short. The really big problem appears if they are long because then they turn into death zones. Make absolutely sure that you avoid long hallways without any alternative ways or enough cover, especially between important areas.

Spawn points

Placing the spawn points is a very important part of your level design but a lot of people simply finish their levels and throw in their spawn positions sloppily. A good placement is the base of your levels and is normally the first experience the player has in your level. Okay, I hope that points 30m above the ground were due to not enough sleep or a wired code bug. In general, the spawn points should have a minimum of 0.5m - 1m (different from game to game) between each other and the people should spawn as a solid group, and shouldn't appear somewhere else (e.g. at the 2km long beach.)

Additionally, it is important to avoid spawn campers (people who wait next to the spawn points and kill player as soon as they appear) because this is extremely frustrating. One possibility to avoid spawn campers is to split into several smaller groups with different positions. Another solution is placing a lot of spawn points so it is difficult for the camper to predict where the player will spawn. Of course, you should try hard to avoid camper positions next to the spawn points (e.g. with walls, sight cover or one way doors). Placing the spawn points in the middle of a big open field where a

mass of campers just have shooting practice against completely helpless players is obviously stupid.

You should also take care about the direction of the spawnpoints. If the player first has to make a 180° turn until he knows where he is and which direction he has to go, even the worst camper has all the time on earth to kill him. The killed player might be a little bit frustrated and confused. The easiest way is to let the player look in the direction he has to go and have absolutely nothing to camp for behind him. Especially people who play a map for the first time normally just start walking in the given direction. If the first seconds of the map are already frustrating and confusing, the map will be rated badly and people will give up playing very quickly.

Also, keep the spawn point a little bit away from the mission objective, otherwise you die while defending it and respawn next to it again. This is simply not fair to the attackers who have managed to come so far. On the other hand, the attackers can quickly move a few additional meters and become spawn campers because they can see the start positions from the mission spot. If they have to move a few more seconds to the spawn points, it's very rare that they wouldn't prefer to win the match or to get a point at the mission goal instead of becoming spawn campers. Of course, there will be always kiddies who will do it but just try to follow some of the hints above and it shouldn't be as much of a problem.

Stopping the Player

I guess a lot of designers don't really think how to stop the player until they are already deep into building their level. The barriers to stop the player leaving the level or to reach special spots sometimes look like quick solutions.

In general, you can say that invisible walls should be prevented as much as possible. Personally, I have fewer problems using an invisible wall to block a street which would lead out of the map if there are some other obvious elements which show the player that the street is blocked. Some simple, easy to see road blocks where the player can't jump over is, in my opinion, okay. The same goes for special fences which I only use to surround the level and are impossible to pass. Of course, a natural or realistic border is much better, like houses, high walls, mountains, etc. but if your map is a village which is surrounded by rocks it feels unrealistic. Especially in maps for non-arcade games, you should really try to prevent that 'arena-feeling'. Other smarter solutions are, for example, water which pushes the player back with the flow, or to create a mix out of the different elements.

Other barriers can be used to stop the player reaching spots inside the map (e.g. to prevent them from jumping on a roof which wasn't planned to be reachable). If the player can reach such spots by just jumping or using special moves, it is normally bad level design! As soon as the player uses 0.1 cm wide trims, just add an invisible ramp that he slides down. If the trim is obviously passable, then please don't use invisible walls, just make the trim smaller. The same goes for slopes; if the player can jump up the hills in your game, make them steeper or stick a rock inside. Adding invisible walls here is just lame.

Something different is if the players use some kind of 'human ladders' to reach higher positions. To a certain degree it is cool to support teamplay but if you need 4 or more people to reach the roof of a house, it will completely destroy your game design and balancing. I think it's fair to use invisible walls to stop these extreme possibilities. Unlikely arcade games places which you can reach with extreme moves like rocket or grenades jumps should be prevented in realistic games,

too. On the other hand, it's quite rare that a game calls itself 'realistic' and you can survive such moves.

Tactical Summary

The player might feel your well balanced strategy plans but he will always see and get in touch with your tactical elements as well. Balancing them is much more difficult because players will always give their best to find weak spots and use them for their advantage. It doesn't matter if they find an extremely advanced sniper position where you didn't intend to have one, or if they start to camp in the hallways instead of fighting in the battlezones. On one hand, players seem to be stupid because they don't do what you want but, on the other hand, they are smart enough to destroy your map if you haven't planned it well.

Try to ask friends how they would move through your map, where they would camp or which area is, in their opinion, unbalanced. Don't be surprised that multiplayer is normally played by several human beings and they all play/feel it differently. If you have played a lot you should know what normally works in other designer's maps and what kind of elements are good and bad.

Experience and fair criticism from your fans/friends/teammates are still the best way to polish your map. A good map simply has to grow like a good painting and it won't get better by itself. Especially today, multiplayer is bigger and more complex in terms of gameplay and level design so it is impossible that your very first version is already perfect. Ignorance and arrogance are the poison of the community. Of course, people will always fight and argue but please try to be more or less fair and try to respect the opinion of your friends and fans.

Navigation/Orientation in the Levels

Introduction

I think it's nothing new for level designers that they have great concepts for a really complex and cool map but as soon as they release it, nobody is playing it on the servers. Especially big maps are simply too large and misleading. Of course, the designer knows the map inside out but people playing it the first time get lost, are frustrated and will never give the map the chance it might deserve. Not without a reason, small levels with very simple design are often the most successful ones. This is the reason why it is very important to give the player a lot of guidance and landmarks which helps them to orientate. Of course, if the game you create the level for supports big open fields, maps in his HUD, or compass with waypoints, it's less important. But even here you should never neglect adding navigation spots and to split the level into recognizable parts. Never forget that, if the player gets lost in your map the first time, it doesn't matter how great your gameplay ideas are because he will never experience it and will switch the map/server in frustration. Orientation and navigation are very important for the success of your map, I can tell you this from my own personal experience.

Eye Catcher/ Special Areas

As I have already mentioned above, one of the best ways to help the player orientate in more complex levels are special eye-catchers or special areas which the player will remember. If you remember the last examples for the BOMB and CTF modes, I split the level into different, very unique parts which gives the player the first basic understanding of where he is. As soon as he knows that he is around the harbor area and not in the backyard he might remember what to do if he comes here again. Especially for team communication, it's a great help. After a few minutes or rounds, there will be a simple pattern of different areas in the mind of the player and he will start to use this for tactics and he can choose his route with purpose. For example, he knows that the harbor area is more medium and long range but after it there are the warehouses which will lead directly to the mission objective. He knows it is short range and CQB so he should be careful and take the right equipment. If the whole map looks very similar, it doesn't really matter if the designers have placed a few more rockets here and a few more plants there. For the first impression of the player, everything will look the same and the map will become uninteresting or at least frustrating. Light settings, architecture, vegetation, styles, textures, furniture, visual range, and sound should vary as much as possible in your map but should also be consistent in the different areas! On the other hand, don't make it too extreme because if the player has to remember too many different areas or styles it becomes confusing and the result would be the same if everything looked the same. There have to be just a few easily memorable and very distinguishable landmarks.

This is the first step for the player to get a very rough understanding. It is similar to your strategic planning, but now the player needs help to orientate himself in more detail. In the end, it doesn't really matter if the player knows he is on the beach or in the jungle if he doesn't know where to go. What is the right direction or where might the enemy come from? Now you should add some special objects or elements which help the player to navigate in detail. For example; the player runs into a house and around some corners and as soon as he comes out he already lost orientation. If he then sees a nice looking red car at the right side and cool graffiti on the wall on the left side, he might remember. The next time he might choose the left side because the way passing the red car only leads back around the house. Of course, this only works if you only have one nice looking red car and one such special graffiti in your level. Other objects can show the direction: if the blue player runs out of the jungle on the beach and he sees a boat wreck he might

remember that the nose of the sailboat leads to the red base and he had better use the other direction. Such small clues and unique elements can be extremely helpful. Things which the player can already see from a long distance or things that are visible the whole time are even better. A big crane which is visible and always points in the same direction, a skybox with a sunrise on the right side, or a big tower with several bright lights in the middle of the maps are other examples. At least at every cross or on every big area you should have such elements.

Overview/ Understanding of the Level

Such hints mentioned above might help the player remember the map quicker but the very first time he still doesn't know exactly where to go. That's why overview and quick understanding of the map is even more important. Try to think about that when you make your strategy plans. First of all, when the player starts he should already spawn in the right direction so he only has to go straight. Around the spawn points the layout should be quite simple and absolutely not complex! Really try to strongly guide the player in the first seconds or let the player see several exits/entrances which he can choose from but then no more cross-routes before he comes to the first battle areas. A good, recognizable part of the level at the beginning without any conflict with the gameplay also helps a lot.

The main routes should be very obvious. If you play the map for the first time, the chance that you first follow the bright bigger hallway is much higher than if you choose the darker, smaller alternative route into the battle area. At the beginning, the player should be guided by easily recognizable routes and, as soon as he knows the map a bit better, he will start to try the other ways and with the elements in the previous topic he will quickly be able to connect the different ways. This is the reason why you should split your levels with urban settings in battle areas and have connections between them. The player will go into the area and the only exits are easily visible. Logically, a level with just a mass of small rooms and hallways is much harder to learn than a well structured one.

Different Level Sizes

The size of your level has a huge impact on your gameplay and is heavily influenced by the game mode, whether you have vehicles, and the game you create the maps for. For example Battlefield 1942 maps simply has to be bigger than a normal Raven Shield map because in one game you have vehicles and in the other game you play some kind of a S.W.A.T. team.

Okay, vehicle maps should be obviously big and quite open. So what kind of criteria should these big maps have? They should be very open because a big map with static routes is either very complex with a lot of alternative routes (which only confuse the player), or they are boring because you can't switch the route for half a minute. Short maps should be very compact but be careful that they don't become too boring by limited possibilities. You have to find the perfect compromise between pliability, navigation, orientation and still guiding the player somehow. Bigger maps are generally for more players but please make them wider instead of longer! Nothing is more annoying than having to walk for half an hour before something happens. On the other side, it is bad to create maps which only start to flow if the server reaches the maximum number of player for the game. If the game only supports 32 players then a big map should already become really fun with 20 people and even with 10 people it should still be entertaining. It's better to create maps which are really fun with just half of the players so you are flexible and the chances of the map being played on both small and large servers is much better. Let's first talk about non-symmetrical mission based game modes like BOMB and discuss how big you want to build your map. The times you can see here are just examples and in the real game they will never be so exact.

Non-Symmetrical Mission Layout

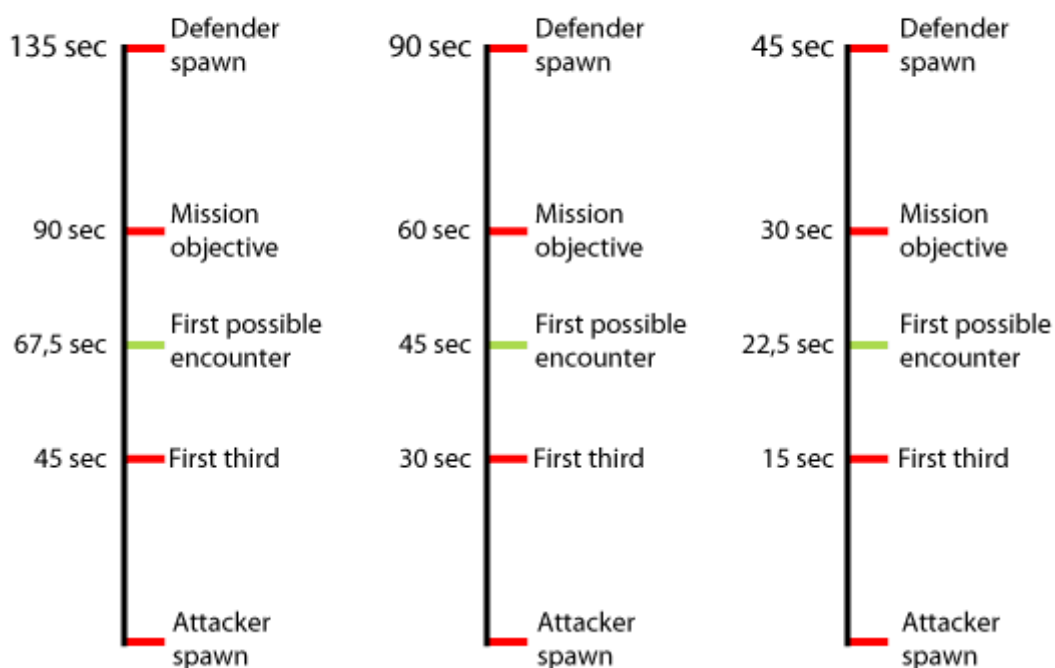

In general, the attacker team should need two times longer to the mission goal than the defending team. So I've drawn three examples which you can see above. The first third of the attacker's route is where tactical possibilities should really start at the latest. Here, the ways should start to split. The amount of cover increases and the player should start to take care instead of just blind

rushing. In the first third there should be absolutely no possibility for base campers! In the first example the attackers need 90 sec to reach the mission objective. Some people might say that this is not a long time for a really big map but if you look at the time where the player might have their first encounter then you see it is 67.5 sec! Do you really want to walk/drive for over a minute before the action might start?! Probably not, so a 90 sec map is definitely too big for the mass player who wants to have quick action. For the second example the attackers need 60 sec to reach the mission spot and the first action might take place at around 45 sec. For me, that sounds like the maximum passage of time for a map that will have some success. Of course there will be always hardcore tactical players who don't care how long they walk, but this won't make your map universally popular. The last example is shorter with 30 sec to the mission goal. With 22.5 sec to the first encounter, it is a pretty fast one. If you make it even shorter, there is a high risk that fast defenders will come too close to the attacker's spawn positions so be careful. Some good advice is that short/fast maps should have a lot of urban elements because in purely outdoor maps it's very hard to control the speed and the routes that the players take. If it's not really a swamp map with a lot of fog, the distance a normal player runs in 22.5 sec is definitely shorter than the normal view distance in modern outdoor maps. So be very careful with snipers/campers around the spawn points.

Now let's look at how the same numerical example looks like with symmetrical maps and with no clear defenders and attackers like CTF.

Symetrical Mission Layout

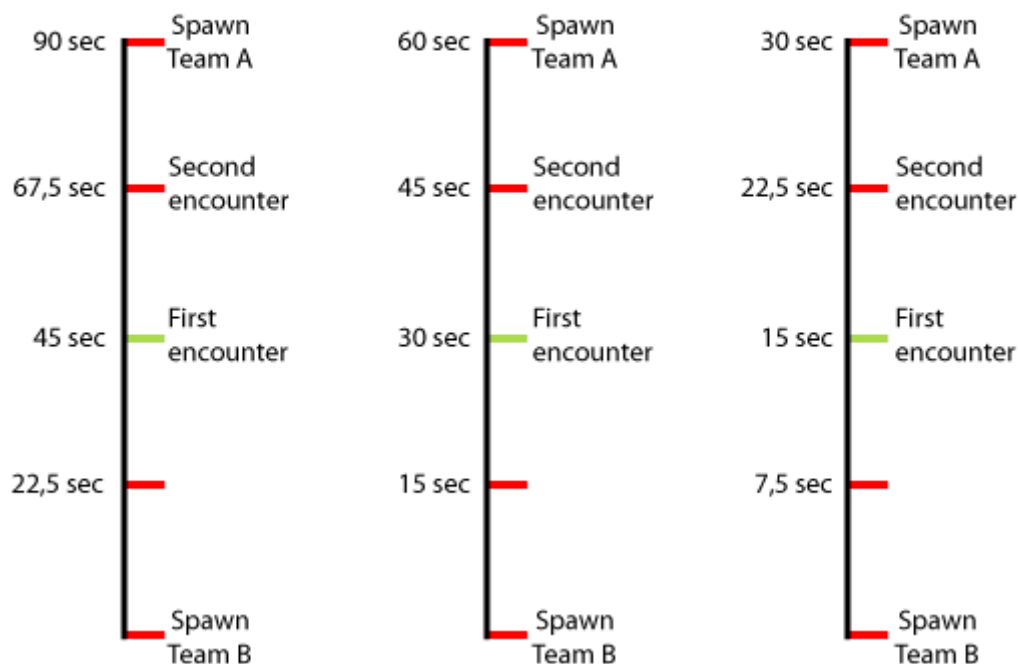

The times are from a case where, when the match starts, a perfect player from team B makes an attack against team A, grabs the flag and runs back to score with it. In the first example you would ideally need 90 sec to reach the mission goal. After around 45 sec you might meet your first enemy. If the dead player respawns at once and starts running straight away, the attacker from team A can encounter him again after 67.5 sec if he hasn't lost any time in the first fight! After another 22.5 sec, he can finally reach the flag and might already kill another player and now has to run back for another 90 sec. All in all, these are three minutes of an absolutely perfect

attack and, as we all know, a perfect run without any lost time in a normal CTF match is almost impossible. So if you try it very often and walk around a lot you will usually need longer than 180 sec which is, in my opinion, already too long. Remember that in a normal CTF match you cannot even roughly calculate where the players will fight because of the normal re-spawning system in such game modes. The second example also takes a long time if we think that this is the most perfect way. But here, the action is already much more packed. The two minutes of intensive possibilities for action sound much better for a big, enjoyable map. However, it is realistic that for a normal run you might still need around three minutes which is borderline. Now in the last example, 30 sec to the enemy's base seems to be suddenly very short but they remind us more about the fast, thrilling CTF matches which we had with the Quake and Unreal games.

Personally, I have less problems to run a between one and two minutes to capture a flag but they should be loaded with action which can only be achieved in medium or small CTF games or in big maps on big servers. So the bigger you plan such a map, the more open the map should be, otherwise the action would be too rare. On the other hand, small maps should be more compact because then tactical gameplay is even less important than pure combat skills.

Art for Gameplay

Introduction

In this section I don't want to talk how to make your level look beautiful. It is more about how art elements like lighting (Visibility), textures (Orientation) and architecture (Movement) might effect your gameplay. It might be that I've already talked about some of these tricks in some of the earlier examples but now I want to complete the list and bring some of those ideas together.

Such elements can be in harsh contrast with the art factor which will make your level look nice and the art will support gameplay. Like in single player games, discussions between the art department and game designers or AI programmers can be daily. In general, the gameplay should rule over aesthetic aspects because fun is more important than "visual brain wanking". First design your levels and if you are the first time somehow satisfied with the final playability, start to make the level look nicer with less important details and color arrangements.

Lighting

Like I already mentioned above, the main intention of using light for gameplay is definitely visibility. The brightness of an area affects the general speed of action and movement.

In a gloomy/stealth part of your level, the player will normally move more slowly and carefully than in a bright one, except in the case of quick surprise actions from an ambush or a camper. Also, dark areas give the player a higher chance to navigate through the area unseen but not completely unheard. I will talk later about sound for gameplay but, for now, don't forget that in darker areas, sound become more important then in strongly illumined ones. So your stealth ways should be generally darker then the fast ways for rushers. Even in outdoor maps with a day setting, you can influence the brightness with shadows from hills, buildings or trees. The darker a section is, the better camouflage works. So even a little bit of shadow can help a lot in the jungle. In some examples, darkness can almost completely eliminate cover. Just imagine a bright base which one team has to assault which is surrounded by pitch black night. The attackers can move around it almost unnoticed without losing sight of their goals. They will become big problems as soon as they come closer, but this offers them a completely different style of tactics than the normal "running-from-cover-to-cover". Don't forget that such ideas can become weaker if the game you design for supports nightvision, flashlights, flares or similar equipment.

I think it is slowly becoming clear that darkness can be used as a tactical element so let's talk about brightly lit areas. In these areas it is much harder to hide so a player might move faster. Because he can see the enemy much better, the action will be generally much cleaner and faster. Visual detection is much more important than sound detection so these bright ways are the preferred ones for rushers where reflex and good aiming are more effective than tactics. For the ambitious tactical hardcore player, this might seem frightening at first blush. On the other hand, real team play can now really be the difference. While moving from cover to cover, other team mates have to be wary of possible spots where the defenders appear and make quick pop-up attacks. Such quick defending strikes are much easier in bright areas so while running forward you simple have to trust your back-up team. Good real-world examples are actually indoor paintball matches. Camouflage is normally absolutely useless because of the colorful sports suits and the fact that you can die after one hit. Fast reflexes are of high importance but you need good support guys to keep the enemy busy and behind their cover.

The second gameplay factor of light is the help for orientation. If the player jumps down into a big

cellar, he can quickly recognize it by the lighting. Bright light can lead the player on the main route, and color schemes can show him on which side of the CTF map he is located.

Textures

Textures affect the gameplay completely differently to lighting because the main purpose is navigation and orientation instead of visibility. Of course, the textures also affect visibility but first let's talk about its main intention.

In arcade CTF maps, the bases have normally blue or red textures and not without good reason. As everybody knows, it helps the player to know exactly which base he is located in. In maps with a realistic setting, it might very stupid if the terrorist base has blue stripes and the S.W.A.T. spawn point has blue ones as well, so let's think about other solutions to use the textures as an help for orientation. The best way is actually to separate the maps in clearly different areas like we already did during the strategy planning phase. For example, a harbor area uses a completely different texture set to a backyard. Try to make sure that the textures are really different. For example; red, clean bricks and a gray, dirty concrete are much easier to recognize as different settings than two standard house textures with slightly different colors. Additionally, the chosen materials have to fit to the area; a wooden high-tech industrial complex simply doesn't look right. Now the player comes into an area which is dominated by brick textures and knows exactly which area he is in.

Large areas with memorable surfaces are even noticeable in a stressful fight or hunt because this is what fills most of the player's screen. Of course these simple hints and only work in maps with a lot of urban elements. In bigger, complex outdoor maps, where the navigation might be different due to a low view range, you should try to use your vegetation as orientation help. Palm trees at the beach, high trees in the big jungle, and small trees in the mountain are just an example, the same goes for grass, bushes or even flowers. For a lot of designers (especially if they've created a lot of SP maps), consistency is very important. In multiplayer, however, it is overruled by gameplay aspects, especially if it helps the player to understand the map much easier. Please don't make the borders between the areas too extreme otherwise it looks cheap. Remember: "In realistic maps the gameplay elements should be hidden as much as possible to create a believable scenario."

As I have mentioned above, textures can also affect the visibility of the player. It is quite obvious that the right surfaces support the camouflage effect of the player skins. A black player is very well hidden in dark, night, urban maps, etc. These things don't need a lot of explanation. If you have a dark cellar and the walls are bright, the stealth effect becomes much weaker. So if you really want to modify the visibility by using light, make sure that the textures fit, too.

Architecture & Geometry

In general, architecture directly affects the movement of the player and, of course, his visibility. One of the main intentions of geometry is actually giving the player cover, so let's talk about the different kinds you can use.

You can create half cover which is only really useful if the player is crouched or prone. It is harder to use and this decreases the effect of it. For balancing a defend/attack position this is a better solution than removing the cover completely because it is better to have weak cover than no cover at all. The second kind is full cover which protects the player completely whether he stands or crouches. This is actually the most powerful and frequently used cover in games; like bigger

trees, columns or edges of houses. Behind such a structure, the player only has to fear indirect fire like grenades and air strikes so try to make sure that the enemy has at least a small chance to counter such a position or to shoot through. For example; a way around, enough cover in front so he can come very close, sniper and support spots to make sure that he stays behind the cover while the rest of the team move forward, or sight cover to sneak close.

Cover doesn't automatically slow down the game flow because here we have two kinds of cover. The first one has only one way around, like a column next to a wall or the edge of a big house. If the player hides there, he is much more predictable for the opposing player. He can only come out at one spot or stay where he is, so movement in such areas will be much more careful and therefore slower. For fast attackers, a route with such cover would become less attractive so move cover next to the walls/borders or make it bigger if you think that the defenders have a disadvantage. The other kind is cover where the player has much more possibilities to surround e.g. a column in the middle of a room, a stone/tree on an open field or a small house. Here, the hiding player has many more ways to surprise the enemy; he can appear at two sides and sometimes he can jump at the top or even go inside. An area with mainly such cover is an eldorado for quick tactical players and normally it's harder to defend. Personally I like such situations with a variety of different possibilities but be careful regarding the balancing. A good counter against it for the defending team are some positions from where you have a good view of almost the whole area like towers, windows, etc.

I think I have already mentioned this above but please don't always use the same kind of cover, especially crates! Of course, they are very easy to build, are very friendly to the performance, and you can get them in almost every size but just try to be a little bit more innovative. Okay, even I used it a lot in my harbour and warehouse maps in this article but only because it is very easy to explain and it is a short word ;-). I've already tried to build maps intending to use as few crates as possible just to see if it's feasible. I mainly used stones, trees, edges, columns, doorways, furniture, big machines, trenches, railings, windows, etc. . Of course, it was possible and the only crates you can find are more decoration than part of the gameplay. If I can do it, you can do it too.

Architecture doesn't always mean cover so use your creativity not only to find different kinds of cover. Try to vary ways to go up and down, not always stairs or ladders e.g. with slopes/piles of dirt, ramps, broken pipes, elevator shafts, crates (or other objects) to jump up, cranes, planks or one way holes to jump down. Then you should think also about ways through walls, not always doors. Try to use windows where the player has to jump through, broken holes in ruins, bigger half open gates or pipes which the player has to crawl through or air ducts. The same counts for ways over trenches or cliffs. Instead of normal bridges, think about planks, fallen trees, pipes, cranes or situations where you can only jump over while running/sprinting.

All of this variety can be easily used to balance the difficulty and speed of routes and to make areas more different from each other. Orientation and navigation becomes much harder if you always use crates, ladders, doors and the same looking bridges. Every time you place such elements, remember if you've already used something similar in your level think about something else instead.

Another important factor of placing architecture or other geometry is the comfortable movement around. Very narrow passages in a battle field should be avoided. If you make gaps between objects then make sure that is obvious that you can't go between. A gap where the player is 2cm too big to fit through is just frustrating. Run around your level and make sure that even for an inexperienced player, the movement is easy and you can't get stuck anywhere.

What about Details and Beauty?

I can't stress enough that performance and gameplay are always more important than the beauty of your map. Of course a nice looking map will get more attention at the beginning but if people notice that the bad performance makes the map unplayable with more than four players, nobody will play it anymore. Obviously the same goes for the gameplay, especially if all of your small details make the player get stuck or cause a very uncomfortable movement. So the main intention of details should be small gameplay elements like a hole/gap in a ruin, curtains around windows, a branch of a tree to jump on or a thin metal railing. The next intention of details is to create the right atmosphere. For example, break walls in ruins and place dirt on the ground, use metal support pieces in warehouses or clean looking furniture in mansions. If you and the players/testers are happy with your map and you have a good performance, start to add unimportant details like broken tiles on the wall/floor, adding a knob to your cupboard, folds in your carpet or make the pipes even more smooth.

Don't go crazy with adding details in your multiplayer maps, normally player just runs through your rooms and as soon as the action starts nobody cares that you wasted 3000 polygons for the picture frame around your favourite FHM model. If you think that an area has a lack of details then first try to use textures or shadows. You can easily combine it with gameplay e.g. a cellar room: Place your lights so that the cover casts a lot of shadows on the walls/floor, use different wall textures, make the unimportant and boring areas much darker than the good looking ones, add some simple structures under the ceiling and throw some dirt on the ground. Normally that's already enough to make a room prettier using the existing elements without wasting a lot of time adding scratches in the walls/floor or placing high poly objects. Of course such hints are very general and I absolutely don't want you to make your maps ugly. Especially the main areas need special attention art wise because beauty is also very important for the first impression but pure art aspects are not part of this article. If you are interested in beautification, don't forget to check my other article(s) (more will come in the future) regarding art.

Sound for Gameplay

Personally, I rarely used sound in multiplayer maps except to create atmosphere. Maybe because I created my maps in the good old days when surface textures with different walking sounds were something pretty new. Especially in areas where visibility is less important than sound detection. For example, in a dark room where you can normally sneak through very silently, some louder metal/glass plates are interesting and fresh gameplay elements. The same can be said for water passages because it doesn't only makes you slower, it is also a different, louder sound and every enemy in the vicinity can hear that there is someone in the water. Such small gameplay elements will become more interesting with better technology so don't forget about them if you create maps for the new cutting-edge games.

I also saw that several designers used to trigger sound elements if you move through specific areas, like a barking dog if you use the route through the backyard. Personally I don't like such things because there is no fair way to avoid them ... hmm unless you can throw a grenade over the fence to blow up the stupid mutt ;-). Something different are mission/game specific sound events like an alarm siren triggered by the enemy or pick up sounds of the flag/mission objective. They can of course be used to balance bigger maps with several objectives.

Round Based vs. Reinforcement Game modes

There are two main differences in making levels for round based game modes and game modes where the players re-spawn constantly. The first one is the size of the maps. If the player spawn in the same positions every round, he doesn't want to walk for very long before the fights start. Of course this is similar to maps for reinforcement game modes but in a round based mode, the people stay dead until one team wins. So the number of possible fights is much more limited and so is the size of the maps. Especially the rounds should be quite short because dead people have to wait for the round to end before they re-spawn again. So a bigger map will become quite boring, people have to walk a lot and dead people stay dead for a long time and get frustrated.

On the other hand, round based game modes can be much more tactical because the start situation is always equal in every round. You can calculate tactical situations much better because you know more or less where the main battle areas will be. For you as a level designer, this makes the design easier but bad places have a much bigger impact on the level design than in re-spawn maps. On such maps an unbalanced area is less critical because almost the whole map can be a battle ground. For example, a powerful defending sniper position can ruin the fights around a mission area every round, and the attackers will avoid the area as much as possible. If the player re-spawns continuously, such a sniper can be nasty, too. But as soon as he is finally dead, the fights might start to move to other places or they never really happen. Fights in such maps are less focused on certain areas but this doesn't mean that you are allowed to create a few unbalanced parts of the map. Both game types require a different design philosophy. One needs perfect focus on certain areas while the others must be a unit of well combined battle areas or just one huge battle area.

Mirrored vs. Uneven Map Layout

It is a well known fact that the arcade game modes like CTF must have a mirrored map layout. This is okay as long as the maps stayed small with no vehicles and the gameplay was very arcadey. Since we can build bigger maps with vehicles and the main intention is to create a realistic feeling battle field, even unmirrored layouts became usual for CTF and similar game modes. This is, of course, nothing new for round based games with normally clear attackers and defenders. If the role of the team is clear, it is easier to calculate the balancing progress.

Mirrored maps are generally easier to build and to balance. They should be used for open and arcade game modes where the realistic feeling of the level is less important than the pure gameplay itself. For example, if you play CTF it is already unrealistic and then it doesn't really matter if one side of the city has blue paintings and the other side is almost the same with more red on the walls. The biggest problem now is to find a good solution to increase the orientation and navigation because you have two parts which are very similar. Of course you could make all the trees on one side red and the other side blue but I hope we all agree that this would look stupid even in fun maps. For a realistic scenario you should try to find much smarter solutions. Like I've already mentioned above, variation is quite important so why shouldn't the bridge on one side be a couple of pipes and on the other side a few wooden planks. This can be used almost everywhere as long as the gameplay at both places stays the same, for balancing reasons. Another idea, which can be well combined with the previous one, are different styles in the areas. One side of the map is dirty with broken old cars and a lot of graffiti and the other side is a more clean, noble area where the house owners wash their cars every weekend. I think it is logical that the break between the two styles shouldn't be very abrupt and should make a little bit sense. If there is absolutely no way to separate the two parts style-wise, you can still go back to the old school "colour solution". Using blue and red should only be your last way. Just don't make it so extreme and artificial like you know it from pure arcade games like Quake. Colourful banderols around trees, graffiti on house walls, marks on crates, cars or even flags are not great ideas but still better than any extreme solutions like blue vs. red grass. Just make sure that it fits as well as possible or that it looks like a paintball team marked their combat areas. A completely blue stone looks way too freaky but if it looks like that someone painted a big blue square on the stone it is already much better.

Unmirrored levels have the complete opposite problems than the mirrored ones. On one hand, if you do it a little bit smart and follow the basic rules in the previous chapters above, navigation and orientation won't be a big problem. On the other hand, now balancing is your biggest issue. That is the reason why unmirrored levels are much harder to design than mirrored ones. Making a few different textures and placing a few detailed objects doesn't need a lot of design skills compared with making a perfectly balanced map with two different sides. I've already talked a lot about how to balance unmirrored maps for round based game modes so this time I will concentrate more on how to do this for reinforcement levels. If your battle fields are very big and open, it is easier because a flat hill is almost the same as a flat valley. As soon as the terrain is really different and you have a lot of bigger objects, balancing starts to become difficult. For example, if at one side you have a bigger hill in front of the regular base defence, the attackers might have an advantage but on the other side you have a valley. Now you need to think about what you have to change so that the attackers have more problems with the hill, or how much cover you have to place in the valley so it is balanced again. You have to think about almost every place in the map and how to balance it differently to the other side. This is very critical and because it is almost impossible to calculate all kinds of combat situations, it is actually impossible to balance it perfectly. The only real solution is a lot of experience and a mass of testing the map

if you want to create an unmirrored level where both teams have the role of attackers and defenders. Expect that the first versions of your maps get a lot of bad feedback and you will have to tweak it a lot. So stay in close contact with your test team and make a detailed test plan. After the first general tests you should start to concentrate on certain areas and let the QA focus on these areas until the feedback is detailed enough so you can really balance them. If you and the test team do the job well, nobody will really notice the small balancing problems. Of course some fans will always complain about this and that area but it will be the minority and is simply the calculated risk of unmirrored maps. Just do it as good as possible.

Realistic & Arcade

Even if your setting is realistic, the game itself can be very different. It can be something ultra realistic like American Army or something more arcade like Action Quake. The strategic design for both kinds of extremes is almost the same. They all need a balanced basic structure and good navigation/orientation. The real differences are in the tactical elements.

If the player can only move realistically for the majority of the game the player it is quite slow. If the player dies very quickly, tactical team play und unpredictable gameplay are the key game elements instead of rushing and making crazy stunts. Cover should be closer together and in bigger battle areas, support/cover spots for the attacking squad become very important. Always think about camper and sniper positions and how the opposing team can counter them with tactics. If one hidden sniper can cover the edge of an important house and the attackers can only peek around the corner and get a headshot or run for four seconds over an open field with no support from the back, it might become quite frustrating. If the first three squad mates have to die before you know where the damn sniper is lying, you should increase the tactical variation heavily. On the other hand, if one 40mm grenade can be fired accurately over 200m and kill everyone in a radius of 5m, the defenders also need the possibility to become unpredictable. In a realistic game it is simply a fact that the defenders have a huge advantage. So if the attackers want to be successful they have to change the tactics very often, use smoke grenades, counter sniping, covering fire, etc. to break through the defense lines. You as the designer, have to give them all these possibilities and if the players don't use them and keep playing like rambos it is simply their fault.

On the other side, if the player can run with 50 kilometres an hour, he has to care less about snipers if he has to sprint four seconds to another cover spot. Taking the risks and cool stunts are strong elements for the fun factor of more arcade game modes. Yes, it was simply cool in Action Quake to strafe, jump 20m to the next roof and surprise the other team. Just make sure that such cool stunts are possible in your maps, the fans will really like to make completely crazy actions. Now campers and lame phlagmetic base defenders have no chance and the whole game becomes faster and more aggressive. Now a single rambo player can wipe out a complete noob team with less problems, but hey that is Hollywood action and the player's problem, not yours. As long as the rambo player can do it in every team because your map is well balanced, it should be okay. It is your job as a level designer to support the features of the game you build for. If you make your map so extremely hard and boring for attackers and defenders, that it is the same as playing an ultra realistic game, you definitely did something wrong.

Game design vs. Level design

I guess what I am telling some of the level designers out there might come as a bit of a shock. From my experience of working with a lot of other designers, quite often they would complain about the game design without thinking that something with their level design might be wrong. Normally there is a fine line between game design and level design but smart people are able to think in the right way and know where the problem might be. So my advice for the level designer with problematic areas in their maps is to consider that there is a fair chance that it can be his fault, too.

For example, the game designer decides that all thin wooden planks are destroyable. Now the level designer complains that he sometimes need undestroyable boards because otherwise the opponent can destroy the only cover in that area very quickly. He decides that some of the planks in his level can not be damaged. Okay, if something has special features it should be obvious that all similar objects have the same abilities. Continuity is an old school design rule and should never be changed. If you have problems with one of the special objects in that specific situation then you simply shouldn't place it there. Just use your brain and think about another solution like a lower stone wall as cover or whatever. Causing frustration and perplexity is the last thing you want in your level.

I know that you are now waiting for an example where the game design is wrong instead of the scolded mapper. Especially the problem of badly designed/balanced weapons shouldn't affect the level design. If a flashbang blinds everyone in a radius of 50m, the designer shouldn't make too many small areas in the level. Frag grenades which you can throw through the whole level and it remember more about artillery shouldn't produce levels where every wall is 30m height. Before the submachinegun is too powerful and the mappers only design wide open fields in their levels, they should start a small revolution against the game designers. I guess since you've read the article this far, you have enough experience to remember enough of the other examples. Discussions are good as long as both sides are able to accept that they might be wrong, and are able to make compromises.

Creativity

I could probably write a completely new article on the subject of creativity but I would like to keep this short. If you read through the whole article, please don't expect that you can now build the greatest levels of all time. Perhaps you can now create some quite solid multiplayer maps but they are still nothing really special without your own creative input! Every good designer has his systems which he uses to create levels but even the best didn't have their greatest ideas on command. Normally you think about a problem or something which might spice up your level until you get a headache and then suddenly, when you least expect it, you find the solution. Great ideas can come to you; under the shower, on the toilet, smoking on the balcony, before you fall asleep or whenever you are relaxing. This is normal and nobody can expect you to come up with ideas to order.

Great ideas are born if you don't think about the problem and suddenly it pops up into your mind so try to make sure that you work in a peaceful, inspiring environment without a lot of stress around you. Go out for a walk, customize your desk like a greenhouse (an extreme example but I've seen it done), relax or do something completely different as long as you don't have to think very hard. If you have no real idea about your strategy plan, just use an already approved oldschool one, modify it a little bit and then you might have cool ideas for the tactical parts. At least this is how it happens to me very often.

It is nothing really new that level designers take their ideas from movies, music videos or even from some cheap B-movie style TV series. A single scene in any action movie can already give you the idea of a tactical scene in your new level. Take this as a base and complete it with a strategy plan, do some research about the environment and you will get enough other ideas to fill the level. In the end nobody knows that it was a Bon Jovi video which gave you the mental kick for a kick ass map because it was just the first impulse for your own creative work.

Final Words & Questions

Who am I writing this for? Definitely for the level designers out there. Sharing his own knowledge so that everyone might learn something and improve their skills is becoming a rare virtue in that community. I hope even more people start to write about their experiences because even I still want to learn something new and I bet you guys have even more cool ideas. On the other hand, I hope a lot of non-level designers are reading this long article to get a better idea about the work we are doing every day. It is already science and almost an art to make good multiplayer levels and it seems that the majority of people still don't understand that.

I guess several designers might say that everything they have read here is just a waste of time because it was all logical and everybody knows the basics. However, I think there is a big difference between knowing something and doing what you know! If I think back to some of my maps, I would find many failures even though I was already clear about all of these rules. Writing these basic rules helps me to internalize it and it might also help you to think more clearly about them after you have read this article.

Building a multiplayer map shouldn't normally be a really big deal but to design a good one is even harder than designing a single player map. On the other hand, it is normally harder to build a good, solid singleplayer level. I don't want to start now with the never ending discussion about whether it is harder to make a singleplayer or multiplayer maps. If you have ever built for both for a long time, or even designed them professionally, then you will have your own opinion which you simply have to respect. Other people's opinions have a smaller impact on my one but, of course, I always welcome fair discussions.

Why are you reading this article? I guess you should have a good answer by now because you've already read through my small bible and if you didn't read anything, shame on you ;-). I hope after reading about the well known or boring aspects, you have learned something new and enjoyed reading it.